

MCK500

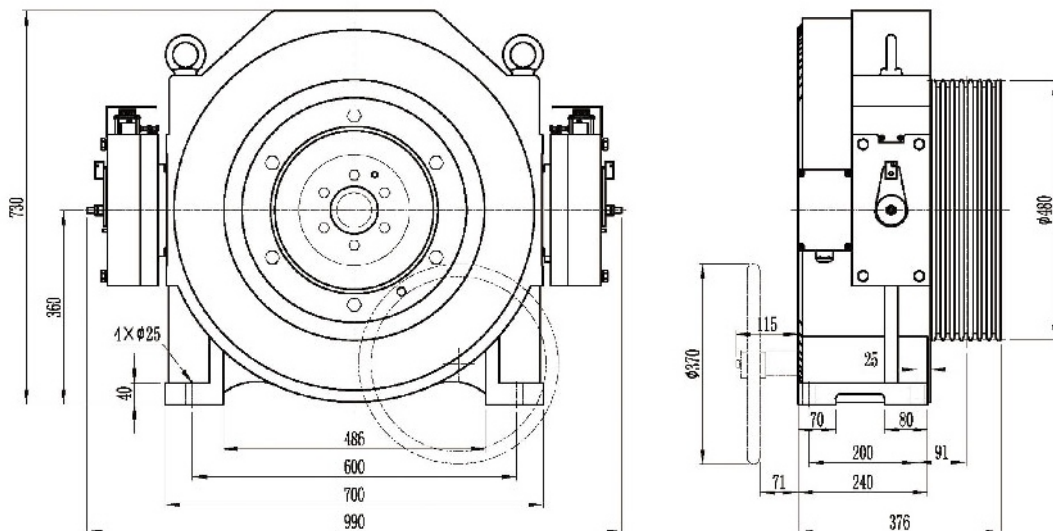

Voltage	380V
Roping	2:1
Wrap	Single
Elv. Load	(1600~2000)kg
Elv. Speed	(0.5~2.5)m/s
Sheave Diam	480mm
Duty	S5-40%ED
Max. Static Load	10000kg
Weight	765kg
Brake	DC110V 2×1.2A
IP Code	IP41
Ins. Class	F

Dimensions



Permanent Magnet Synchronous
Gearless Traction Machine

Spec. Sheet

Type	Spec	Elv Load	Elv Speed	Sheave Dia	Sheave Groove	Current	Power	Speed	Freq	Torque	Poles	Undercut Angle
		kg	m/s	mm		A	kW	r/min	Hz	N·m		°
MCK500	1600-0.5A	1600	0.5	480	6×Φ12×17	18	5.6	40	16.0	1330	48	95
MCK500	1600-0.63A	1600	0.63	480	6×Φ12×17	18	7.0	50	20.0	1330	48	
MCK500	1600-1.0A	1600	1.0	480	6×Φ12×17	27	11.1	80	32.0	1330	48	
MCK500	1600-1.5A	1600	1.5	480	6×Φ12×17	44	16.6	119	47.6	1330	48	
MCK500	1600-1.6A	1600	1.6	480	6×Φ12×17	44	17.7	127	50.8	1330	48	
MCK500	1600-1.75A	1600	1.75	480	6×Φ12×17	44	19.4	139	55.6	1330	48	
MCK500	1600-2.0A	1600	2.0	480	6×Φ12×17	49	22.1	159	63.6	1330	48	
MCK500	1600-2.5A	1600	2.5	480	6×Φ12×17	60	27.7	199	79.6	1330	48	
MCK500	2000-0.5A	2000	0.5	480	7×Φ12×17	22	7.0	40	16.0	1660	48	
MCK500	2000-0.63A	2000	0.63	480	7×Φ12×17	22	8.7	50	20.0	1660	48	
MCK500	2000-1.0A	2000	1.0	480	7×Φ12×17	31	13.9	80	32.0	1660	48	
MCK500	2000-1.5A	2000	1.5	480	7×Φ12×17	53	20.7	119	47.6	1660	48	
MCK500	2000-1.6A	2000	1.6	480	7×Φ12×17	53	22.1	127	50.8	1660	48	
MCK500	2000-1.75A	2000	1.75	480	7×Φ12×17	53	24.2	139	55.6	1660	48	
MCK500	2000-2.0A	2000	2.0	480	7×Φ12×17	61	27.6	159	63.6	1660	48	

Remark:

1. This model could be used for either machine room elevator or machine roomless elevator.
2. AC220V rectifier for brake is optional.
3. The above value of undercut angle is recommended based on regular standard. It's optional according to practical condition.

