

Solenoid Controlled Pilot Operated Directional Valves

These valves are composed of a solenoid operated pilot valve and a pilot operated slave valve. When a solenoid is energised the pilot valve directs the flow to move the spool of the slave valve, thus changing the direction of flow in the hydraulic circuit.

High Pressure High Flow

High pressure [31.5 MPa (4570 PSI)] along which high flow means compact system design.

Lower Pressure Drop

System energy saving increased as pressure drop of each valve has been greatly reduced.

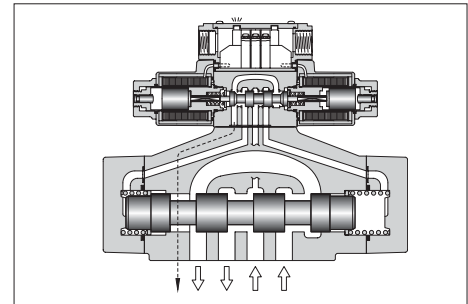
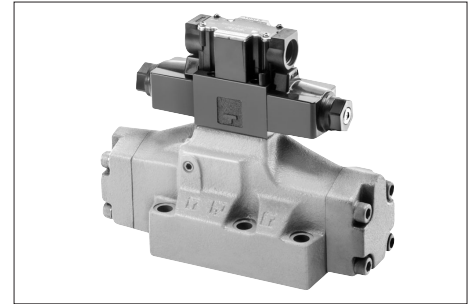

Specifications

Valve Type	Model Numbers	Max. Flow L/min (U.S.GPM) ^{★1}	Max. Operating Pressure MPa (PSI)	Max. Pilot Pressure MPa (PSI)	Min. ^{★2} Required Pilot Pres. MPa (PSI)	Max. T-Line Back Pressure MPa (PSI)		Max. Change-over Frequency Cycles/Min {min ⁻¹ }			Mass kg (lbs.)
						Ext. Drain	Int. Drain	AC	DC	R	
Standard Type	DSHG-01-3C*-*-14/1480/1490	40 (10.6)	21 (3050)	21 (3050)	1.0 (145)	16 (2320)	16 (2320)	120	120	120	3.2 (7.1)
	DSHG-01-2B*-*-14/1480/1490										2.7 (6.0)
	DSHG-03-3C*-*-14/1490	160 (42.3)	25 (3630)	25 (3630)	0.7 (100)	16 (2320)	16 (2320)	120	120	120	6.9 (15.2)
	DSHG-03-2N*-*-14/1490										6.9 (15.2)
	DSHG-03-2B*-*-14/1490										6.4 (14.1)
	Shockless Type	(S-)DSHG-04-3C*-*-52/5290	300 (79.3)	31.5 (4570)	25 (3630)	0.8 (120)	21 (3050)	16 (2320)	120	120	120
(S-)DSHG-04-2N*-*-52/5290		8.5 (18.7)									
(S-)DSHG-04-2B*-*-52/5290		8.0 (17.6)									
(S-)DSHG-06-3C*-*-53/5390		500 (132)	31.5 (4570)	25 (3630)	★3	21 (3050)	16 (2320)	120	120	120	12.4 (27.3)
(S-)DSHG-06-2N*-*-53/5390											12.4 (27.3)
(S-)DSHG-06-2B*-*-53/5390				11.9 (26.2)							
(S-)DSHG-06-3H*-*-53/5390		1100 (291)	31.5 (4570)	21 (3050)	1.0 (145)	21 (3050)	16 (2320)	110	110	110	13.2 (29.1)
(S-)DSHG-10-3C*-*-43/4390				25 (3630)				1.0 (145)	120	120	100
(S-)DSHG-10-2N*-*-43/4390	100								100	100	45.0 (99.2)
(S-)DSHG-10-2B*-*-43/4390	21 (3050)			60					60	50	44.5 (98.1)
(S-)DSHG-10-3H*-*-43/4390						52.9 (116.6)					

★1. Maximum flow indicates a ceiling flow. As the ceiling flow depends on the type of spool and operating condition, refer to the List of Spool Functions on pages 6 to 10 for details.

★2. Pilot pressure of internal pilot drain models must always exceed tank line back pressure by a minimum required pilot pressure.

★3. Min. pilot pressure of with pilot piston in 1.8 MPa (260 PSI).

Solenoid Ratings

Solenoid ratings of pilot valve are identical with those of standard solenoid valve. Refer to relevant solenoid ratings described on the page below.

Model Numbers	Pilot Valve Model Numbers	Solenoid Ratings described on the page below
DSHG-01	DSG-01-***-70*	345
DSHG-03		
(S-)DSHG-04		
(S-)DSHG-06		
(S-)DSHG-10		

Yuken can offer flanged connection valves described below. Consult us for the details.

Model Numbers	Rated Flow l/min (U.S.GPM)	Max. Pressure MPa (PSI)
DSHF-10-***-27*	315 (83)	21 (3050)
DSHF-16-***-37*	500 (132)	21 (3050)
DSHF-24-***-28*	1200 (317)	21 (3050)
DSHF-32-***-27*	2400 (634)	21 (3050)

CSA Approved Solenoid Valve

Available to supply DSHG-06 series valve approved by the CSA (Canadian Standards Association). Consult us for details.



■ Model Number Designation

F-	S-	DSHG	-06	-2	B	2	A	-C2	-E	T	
Special Seals	Type	Series Number	Valve Size	No. of Valve Position	Spool-Spring Arrangement	Spool Type	Special Two Position Valve	Models with Pilot Choke Valve	Pilot Connection	Drain Connection	
F: For Phosphate Ester Type Fluids (Omit if not required)	None: Standard Type	DSHG: Solenoid Controlled Pilot Operated Directional Valve, Sub-plate Mounting	01	3	C: Spring Centred	2, 3, 4 40, 5, 60 7, 9, 10 11, 12	—	—	—	None: Internal Pilot	None: External Drain
				2	B: Spring Offset	2, 3, 4 40, 7					
			03	3	C: Spring Centred	2, 3, 4 40, 5, 60 7, 9, 10 11, 12	—	—			
				2	N: No-Spring B: Spring Offset	2 3 4 40 7					
			04	3	C: Spring Centred	2, 4, 40 60, 10, 12 (3, 5, 6) ^{*1} (7, 9, 11)	—	A^{*2} (Omit if not required)			
				2	N: No-Spring B: Spring Offset	2, 4, 40 (3, 7) ^{*1} 2, 4, 40 (3, 7) ^{*1}	A^{*2} B^{*2} (Omit if not required)				
	06	3	H: Pressure Centred C: Spring Centred	2, 4, 40 60, 10, 12 (3, 5, 6) ^{*1} (7, 9, 11)	—	A^{*2} (Omit if not required)					
	10	2	N: No-Spring B: Spring Offset	2, 4, 40 (3, 7) ^{*1} 2, 4, 40 (3, 7) ^{*1}	A^{*2} B^{*2} (Omit if not required)						

Note: In spool type “3”, “5”, “6”, “60”, and “7”, the combination applicable between pilot system and drain system is as described in the table below.

Pilot Connection	Drain Connection	Care in Application
Internal Pilot	External Drain	Hold back pressure in the tank line so that the difference between pilot pressure and drain pressure is always more than minimum required pilot pressure.
	Internal Drain (T)	Combination is not applicable
External Pilot (E)	External Drain Internal Drain (T)	No restrictions in the combination on us

	-R2	-A100	-C	-H	-N	-53	-*	-L
	Spool Control ^{★3} Modification (Omit if not required)	Coil Type	Manual Override of Pilot Valve	Bult-in Orifice for Pilot Line	Type of Elec- trical Conduit Connection	Design Number	Design Standard	Models with Reverse Mtg. of Solenoid
	—	AC: A100 , A200 A120 , A240		—		14	None: Japanese Standard "JIS"	— L (Omit if not required)
	R2 : With Stroke Adjustment, Both Ends RA : With Stroke Adjustment, Port "A" End RB : With Stroke Adjustment, Port "B" End	DC: D12 , D24 D48 AC → DC R100 , R200	None : Manual Override Pin	—	None: Terminal Box Type	14	90: N. American Design Standard	— L (Omit if not required)
		AC: A100 , A200 A120 , A240	C : Push Button & Lock Nut	—	N: Push-in Connector Type	52	None: Japanese Standard "JIS" & European Design Standard	— L (Omit if not required)
	R2 : With Stroke Adj., Both Ends RA : With Stroke Adj., Port "A" End RB : With Stroke Adj., Port "B" End P2 : With Pilot Piston, Both Ends PA : With Pilot Piston, Port "A" End PB : With Pilot Piston, Port "B" End	DC: D12 , D24 D48 AC → DC R100 , R200		—		53	80: European Design Standard (Applicable only for DSHG-01)	—
				H : Refer to ^{★5}	N1 : Push-in ^{★4} Connector with Indicator Light	43	90: N. American Design Standard	— L (Omit if not required)

★1. Sheless type (S-DSHG) are not available for spool type marked ().

★2. As for the details of the valve using the neutral position and the side position (either SOL a or SOL b side), please refer to [page 11](#). Furthermore, the spool types other than "2", "4", "40" (3, 7) are also available.

★3. In spool-spring arrangement "H" (Pressure centred models), the valves with stroke adjustment (R*) and pilot-piston (P*) are not available.

★4. NI stands for Plug-in connector with solenoid indicator light. NI is not available for R-type solenoids.

★5. In spool-spring arrangement "H" (pressure centred models), in case the pilot pressure is more than 10 MPa (1450 PSI), please specify that the valve should have the built-in orifice to the pilot line.

In the table above, the symbols and numbers highlighted with shade represent the optional extras. The valves with model number having such optional extras are handles as options, therefore please confirm the time of delivery with us before ordering.

Sub-plates

Valve Model Numbers	Japanese Standard "JIS"			European Design Standard			N. American Design Standard		
	Sub-plate Model Numbers	Thread Size	Approx. Mass kg (lbs.)	Sub-plate Model Numbers	Thread Size	Approx. Mass kg (lbs.)	Sub-plate Model Numbers	Thread Size	Approx. Mass kg (lbs.)
DSHG-01	DSGM-01-31	Rc 1/8	0.8 (1.8)	DSGM-01-3080	1/8 BSP.F	0.8 (1.8)	DSGM-01-3090	1/8 NPT	0.8 (1.8)
	DSGM-01X-31	Rc 1/4	0.8 (1.8)	DSGM-01X-3080	1/4 BSP.F	0.8 (1.8)	DSGM-01X-3090	1/4 NPT	0.8 (1.8)
	DSGM-01Y-31	Rc 3/8	0.8 (1.8)	—	—	—	DSGM-01Y-3090	3/8 NPT	0.8 (1.8)
DSHG-03	DSGM-03-40*	Rc 3/8	3.0 (6.6)	DSGM-03-2180*	3/8 BSP.F	3.0 (6.6)	DSGM-03-2190*	3/8 NPT	3.0 (6.6)
	DSGM-03X-40*	Rc 1/2	3.0 (6.6)	DSGM-03X-2180*	1/2 BSP.F	3.0 (6.6)	DSGM-03X-2190*	1/2 NPT	3.0 (6.6)
	DSGM-03Y-40*	Rc 3/4	4.7 (10.4)	DSGM-03Y-2180*	3/4 BSP.F	4.7 (10.4)	DSGM-03Y-2190*	3/4 NPT	4.7 (10.4)
	DHGM-03Y-10	Rc 3/4	4.7 (10.4)	DHGM-03Y-1080	3/4 BSP.F	4.7 (10.4)	DHGM-03Y-1090	3/4 NPT	4.7 (10.4)
DSHG-04	DHGM-04-20	Rc 1/2	4.4 (9.7)	DHGM-04-2080	1/2 BSP.F	4.4 (9.7)	DHGM-04-2090	1/2 NPT	4.4 (9.7)
	DHGM-04X-20	Rc 3/4	4.1 (9.0)	DHGM-04X-2080	3/4 BSP.F	4.1 (9.0)	DHGM-04X-2090	3/4 NPT	4.1 (9.0)
DSHG-06	DHGM-06-50	Rc 3/4	7.4 (16.3)	DHGM-06-5080	3/4 BSP.F	8.5 (18.7)	DHGM-06-5090	3/4 NPT	7.4 (16.3)
	DHGM-06X-50	Rc 1	7.4 (16.3)	DHGM-06X-5080	1 BSP.F	8.5 (18.7)	DHGM-06X-5090	1 NPT	7.4 (16.3)
DSHG-10	DHGM-10-40	Rc 1-1/4	21.5 (47.4)	DHGM-10-4080	1-1/4 BSP.F	21.5 (47.4)	DHGM-10-4090	1-1/4 NPT	21.5 (47.4)
	DHGM-10X-40	Rc 1-1/2	21.5 (47.4)	DHGM-10X-4080	1-1/2 BSP.F	21.5 (47.4)	DHGM-10X-4090	1-1/2 NPT	21.5 (47.4)

★ DSGM-03* is available only for Internal pilot-Internal drain type (Use DHGM-03Y for other valves).

● Sub-plates are available. Specify the sub-plate model number from the table above.

When sub-plates are not used, the mounting surface should have a good machined finish.

Mounting Bolt

Model Numbers	Name	Mounting Bolt			
		Japanese Standard "JIS" European Design Standard	N. American Design Standard	Qty.	Tightening Torque Nm (in. lbs.)
DSHG-01	Mtg. Bolt Kit ★ ³	MBK-01-01-30 ★ ¹ MBK-01-02-30 ★ ²	MBK-01-01-3090 ★ ¹ MBK-01-02-3090 ★ ²	1 set	5 - 6 (43 - 52)
DSHG-03	Soc. Hd. Cap Screw	M6 × 35 Lg.	1/4-20 UNC × 1-3/4 Lg.	4	12 - 15 (104 - 130)
(S)-DSHG-04	Soc. Hd. Cap Screw	M6 × 45 Lg. M10 × 50 Lg.	1/4-20 UNC × 1-3/4 Lg. 3/8-16 UNC × 2 Lg.	2 4	12 - 15 (104 - 130) 58 - 72 (504 - 625)
(S)-DSHG-06	Soc. Hd. Cap Screw	M12 × 60 Lg.	1/2-13 UNC × 2-1/2 Lg.	6	100 - 123 (868 - 1068)
(S)-DSHG-10	Soc. Hd. Cap Screw	M20 × 75 Lg.	3/4-10 UNC × 3 Lg.	6	473 - 585 (4106 - 5078)

★ 1. For Internal Pilot-Internal Drain.

★ 2. For External Pilot or External Drain.

★ 3. Mounting bolt kit is common to that of 01 series modular valves. Refer to figure below for the dimensions of bolt kit.

Stud Bolt

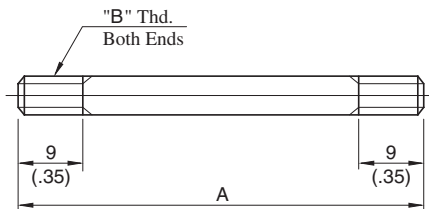

Nut

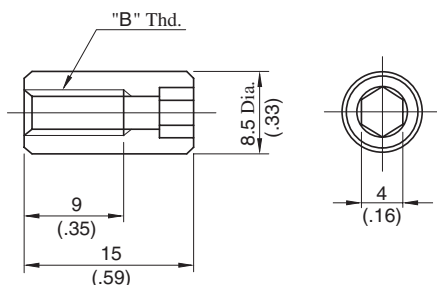

DIMENSIONS IN MILLIMETRES (INCHES)

Model Numbers	A mm (In.)	"B" Thd.
MBK-01-01-30	94 (3.70)	M5
MBK-01-02-30	134 (5.28)	
MBK-01-01-3090	94 (3.70)	No.10-24 UNC
MBK-01-02-3090	134 (5.28)	

Options

Models with Pilot Choke Adjustment

When the adjustment screw is turned clockwise, changeover speed of the main spool becomes slow. In case of the spring centred valves in particular, making slow of the returning speed of the main spool to the neutral position is possible with a C2 choke valve. These choke valves can be used in combination with the valves of spring centred, no-spring, offset, pressure centred and the valves with stroke adjustment.

Graphic Symbols (Ex.: Spring Centred)

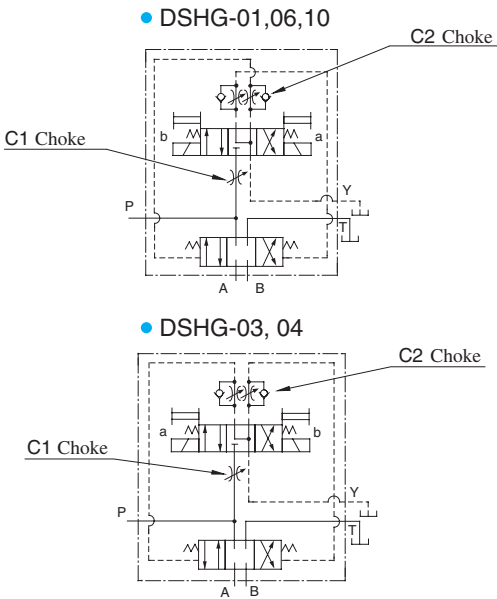

Models with Pilot Piston(P2, PA, PB)

The valves with a pilot piston can be used when the high speed changeover of the main spool is required. However, please note that in case of spring centered valves, there is no change in the returning speed of the main spool to the neutral position even with the pilot piston.

Graphic Symbols (Ex.: Spring Centred)

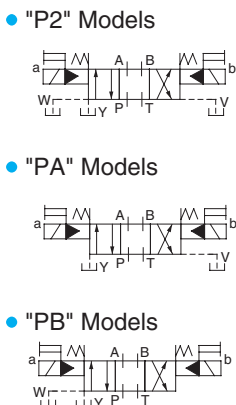

Pressure Centred Models (3H*)

The pressure centered type can be used when the returning of the main spool to the neutral position is required to be firmly.

Graphic Symbols (Ex.: External Pilot-External Drain)

(Only for 3H6, 3H60)

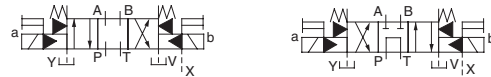

Models with Stroke Adjustment (R2, RA, RB)

When the adjustment screw is screwed in, the main spool stroke becomes short and flow rate reduces.

Graphic Symbols (Ex.: Spring Centred)

"R2" Models

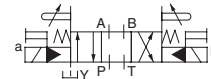

"RA" Models



"RB" Models



Additional Mass of Options

Add the mass described below to the mass of standard models on page 1, if options are required.

kg (lbs.)

Model Numbers	Model with Pilot Choke Adj.		Models with Pilot Piston		Models with Stroke Adj.	
	C1, C2	C1C2	P2	PA PB	P2	PA PB
DSHG-03	0.65(1.4)	1.3(2.9)	—	—	0.6(1.3)	0.3 (.7)
(S-)DSHG-04	0.65(1.4)	1.3(2.9)	—	—	1.0(2.2)	0.5(1.1)
(S-)DSHG-06	0.65(1.4)	1.3(2.9)	1.0(2.2)	0.5(1.1)	1.2(2.6)	0.6(1.3)
(S-)DSHG-10	0.65(1.4)	1.3(2.9)	3.6(7.9)	1.8(4.0)	3.7(8.2)	1.85(4.1)

Options on Pilot Valve

The same options to DSG-01 series valves are available. Please refer to page 345 for the details.

■ List of Spool Functions and Maximum Flow (DSHG-01)

Spool Type	Three Positions				Two Positions			
	Spring Centred				Spring Centred			
	Graphic Symbol 	Maximum Flow L/min (U.S.GPM)			Graphic Symbol 	Maximum Flow L/min (U.S.GPM)		
Model Numbers	7 MPa (1020 PSI)	14 MPa (2030 PSI)	21 MPa (3050 PSI)	Model Numbers	7 MPa (1020 PSI)	14 MPa (2030 PSI)	21 MPa (3050 PSI)	
"2"	DSHG-01-3C2	40 (10.6)	40 (10.6)	40 (10.6)	DSHG-01-2B2	40 (10.6)	40 (10.6)	40 (10.6)
"3"	DSHG-01-3C3	40 (10.6)	40 (10.6)	40 (10.6)	DSHG-01-2B3	40 (10.6)	40 (10.6)	40 (10.6)
"4"	DSHG-01-3C4	40 (10.6)	40 (10.6)	40 (10.6)	DSHG-01-2B4	40 (10.6)	40 (10.6)	40 (10.6)
"40"	DSHG-01-3C40	40 (10.6)	40 (10.6)	40 (10.6)	DSHG-01-2B40	40 (10.6)	40 (10.6)	40 (10.6)
"5"	DSHG-01-3C5	40 (10.6)	40 (10.6)	40 (10.6)				
"60"	DSHG-01-3C60	40 (10.6)	40 (10.6)	40 (10.6)				
"7"	DSHG-01-3C7	40 (10.6)	40 (10.6)	40 (10.6)	DSHG-01-2B7	40 (10.6)	40 (10.6)	40 (10.6)
"9"	DSHG-01-3C9	40 (10.6)	40 (10.6)	40 (10.6)				
"10"	DSHG-01-3C10	40 (10.6)	40 (10.6)	40 (10.6)				
"11"	DSHG-01-3C11	40 (10.6)	40 (10.6)	40 (10.6)				
"12"	DSHG-01-3C12	40 (10.6)	40 (10.6)	40 (10.6)				

Notes) 1. Max. flow shows value at pilot pressure more than 1 MPa (150 PSI)

2. Max. flow in the table above represents the value in the flow condition of P → A → B → T (or P → B → A → T) as shown in the circuit diagram right.

In case the valve is used in the condition that either A or B port is blocked, the maximum flow differs according to a hydraulic circuit, therefore, please consult us for details.

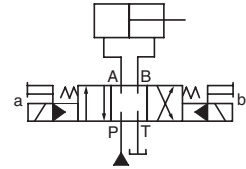

■ List of Spool Functions and Maximum Flow (DSHG-03)

● Three Positions

Spool Type	Spring Centred			
	Graphic Symbol	Maximum Flow		
	Model Numbers	7 MPa (1020 PSI)	14 MPa (2030 PSI)	25 MPa (3630 PSI)
"2"		160 (42.3)	85 (22.5) 160 (42.3)	60 (15.9) 95 (25.1)
"3"		160 (42.3)	160 (42.3)	160 (42.3)
"4"		160 (42.3)	85 (22.5) 160 (42.3)	60 (15.9) 95 (25.1)
"40"		160 (42.3)	85 (22.5) 160 (42.3)	60 (15.9) 95 (25.1)
"5"		160 (42.3)	85 (22.5) 160 (42.3)	60 (15.9) 95 (25.1)
"60"		160 (42.3)	160 (42.3)	125 (33.0) 160 (42.3)
"7"		160 (42.3)	85 (22.5) 160 (42.3)	60 (15.9) 95 (25.1)
"9"		160 (42.3)	85 (22.5) 160 (42.3)	60 (15.9) 95 (25.1)
"10"		160 (42.3)	85 (22.5) 160 (42.3)	60 (15.9) 95 (25.1)
"11"		160 (42.3)	85 (22.5) 160 (42.3)	60 (15.9) 95 (25.1)
"12"		160 (42.3)	85 (22.5) 160 (42.3)	60 (15.9) 95 (25.1)

● Two Positions

Spool Type	No-Spring				Spring Offset			
	Graphic Symbol	Maximum Flow			Graphic Symbol	Maximum Flow		
	Model Numbers	7 MPa (1020 PSI)	14 MPa (2030 PSI)	25 MPa (3630 PSI)	Model Numbers	7 MPa (1020 PSI)	14 MPa (2030 PSI)	25 MPa (3630 PSI)
"2"		160 (42.3)	160 (42.3)	85 (22.5) 160 (42.3)	DSHG-03-2B2	160 (42.3)	160 (42.3)	85 (22.5) 160 (42.3)
"3"		160 (42.3)	160 (42.3)	85 (22.5) 160 (42.3)	DSHG-03-2B3	160 (42.3)	160 (42.3)	85 (22.5) 160 (42.3)
"4"		160 (42.3)	160 (42.3)	85 (22.5) 160 (42.3)	DSHG-03-2B4	160 (42.3)	160 (42.3)	85 (22.5) 160 (42.3)
"40"		160 (42.3)	160 (42.3)	85 (22.5) 160 (42.3)	DSHG-03-2B40	160 (42.3)	160 (42.3)	85 (22.5) 160 (42.3)
"7"		160 (42.3)	160 (42.3)	85 (22.5) 160 (42.3)	DSHG-03-2B7	160 (42.3)	160 (42.3)	85 (22.5) 160 (42.3)

Notes: 1. The relation between max. flow and pilot pressure in the table above is as shown below.

(Example)

Maximum flow rate is constant regardless of pilot pressure.
Pilot Pressure more than 0.7 MPa (100 PSI).

160 (42.3)	85 (22.5)
	160 (42.3)

Pilot Pressure at 0.7 MPa (100 PSI).

Pilot Pressure at 1 MPa (150 PSI).

2. Max. flow in the table above represents the value in the flow condition of P → A → B → T (or P → B → A → T) as shown in the circuit diagram right.
In case the valve is used in the condition that either A or B port is blocked, the maximum flow differs according to a hydraulic circuit, therefore, please consult us for details.

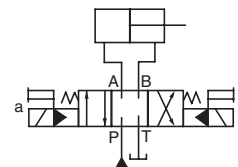

■ List of Spool Functions and Maximum Flow (DSHG-04/S-DSHG-04)

● Three Positions

Spool Type	Spring Centred				
	Graphic Symbol	Maximum Flow L/min (U.S.GPM)			
		10 MPa (1450 PSI)	16 MPa (2320 PSI)	25 MPa (3630 PSI)	31.5 MPa (4570 PSI)
"2"	DSHG-04-3C2	300 (79.3)	300 (79.3)	200 (52.8)	145 (38.3)
	(S-)DSHG-04-3C2	300 (79.3)	250 (66.1)	120 (31.7)	110 (29.1)
"3"	DSHG-04-3C3	300 (79.3)	300 (79.3)	300 (79.3)	300 (79.3)
"4"	DSHG-04-3C4	300 (79.3)	300 (79.3)	250 (66.1)	165 (43.6)
	(S-)DSHG-04-3C4	300 (79.3)	300 (79.3)	140 (37.0)	110 (29.1)
"40"	DSHG-04-3C40	300 (79.3)	300 (79.3)	200 (52.8)	145 (38.3)
	(S-)DSHG-04-3C40	300 (79.3)	250 (66.1)	120 (31.7)	110 (29.1)
"5"	DSHG-04-3C5	250 (66.1)	250 (66.1)	245 (64.7)	245 (64.7)
"6"	DSHG-04-3C6	300 (79.3)	260 (68.7)	245 (64.7)	235 (62.1)
"60"	DSHG-04-3C60	300 (79.3)	300 (79.3)	300 (79.3)	300 (79.3)
	(S-)DSHG-04-3C60	300 (79.3)	300 (79.3)	300 (79.3)	300 (79.3)
"7"	DSHG-04-3C7	300 (79.3)	300 (79.3)	200 (52.8)	145 (38.3)
"9"	DSHG-04-3C9	300 (79.3)	300 (79.3)	280 (74.0)	250 (66.1)
"10"	DSHG-04-3C10	300 (79.3)	300 (79.3)	200 (52.8)	150 (39.6)
	(S-)DSHG-04-3C10	300 (79.3)	250 (66.1)	120 (31.7)	110 (29.1)
"11"	DSHG-04-3C11	300 (79.3)	260 (68.7)	160 (42.3)	140 (37.0)
"12"	DSHG-04-3C12	300 (79.3)	280 (74.0)	170 (44.9)	135 (35.7)
	(S-)DSHG-04-3C12	300 (79.3)	250 (66.1)	120 (31.7)	110 (29.1)

● Two Positions

Spool Type	No-Spring					Spring Offset				
	Graphic Symbol	Maximum Flow L/min (U.S.GPM)				Graphic Symbol	Maximum Flow L/min (U.S.GPM)			
		10 MPa (1450 PSI)	16 MPa (2320 PSI)	25 MPa (3630 PSI)	31.5 MPa (4570 PSI)		10 MPa (1450 PSI)	16 MPa (2320 PSI)	25 MPa (3630 PSI)	31.5 MPa (4570 PSI)
"2"	(S-)DSHG-04-2N2	300 (79.3)	300 (79.3)	300 (79.3)	300 (79.3)	(S-)DSHG-04-2B2	300 (79.3)	300 (79.3)	300 (79.3)	300 (79.3)
"3"	DSHG-04-2N3	300 (79.3)	300 (79.3)	300 (79.3)	300 (79.3)	DSHG-04-2B3	300 (79.3)	300 (79.3)	300 (79.3)	300 (79.3)
"4"	(S-)DSHG-04-2N4	300 (79.3)	300 (79.3)	300 (79.3)	300 (79.3)	(S-)DSHG-04-2B4	300 (79.3)	300 (79.3)	300 (79.3)	300 (79.3)
"40"	(S-)DSHG-04-2N40	300 (79.3)	300 (79.3)	300 (79.3)	300 (79.3)	(S-)DSHG-04-2B40	300 (79.3)	300 (79.3)	300 (79.3)	300 (79.3)
"7"	DSHG-04-2N7	300 (79.3)	300 (79.3)	300 (79.3)	300 (79.3)	DSHG-04-2B7	300 (79.3)	300 (79.3)	300 (79.3)	300 (79.3)

Notes: 1. Max flow described above shown value at pilot pressure more than 0.8 MPa (120 PSI).

2. Max. flow in the table above represents the value in the flow condition of P → A → B → T (or P → B → A → T) as shown in the circuit diagram right.
In case the valve is used in the condition that either A or B port is blocked, the maximum flow differs according to a hydraulic circuit, therefore, please consult us for details.

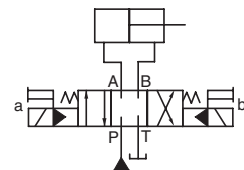

■ List of Spool Functions and Maximum Flow (DSHG-06/S-DSHG-06)

● Three Positions

Spool Type	Spring Centred					Pressure Centred				
	Graphic Symbol	Maximum Flow L/min (U.S.GPM)				Graphic Symbol	Maximum Flow L/min (U.S.GPM)			
	Model Numbers	10 MPa (1450 PSI)	16 MPa (2320 PSI)	25 MPa (3630 PSI)	31.5 MPa (4570 PSI)	Model Numbers	10 MPa (1450 PSI)	16 MPa (2320 PSI)	25 MPa (3630 PSI)	31.5 MPa (4570 PSI)
"2"	(S-)DSHG-06-3C2	500 (132)	500 (132)	410 (108) 500 (132)	310 (81.9) 500 (132)	(S-)DSHG-06-3H2	500 (132)	500 (132)	500 (132)	420 (111) 500 (132)
"3"	DSHG-06-3C3	500 (132)	500 (132)	460 (122)	370 (97.8)	DSHG-06-3H3	500 (132)	500 (132)	500 (132)	500 (132)
"4"	(S-)DSHG-06-3C4	500 (132)	500 (132)	410 (108) 500 (132)	310 (81.9) 500 (132)	(S-)DSHG-06-3H4	500 (132)	500 (132)	500 (132)	420 (111) 500 (132)
"40"	(S-)DSHG-06-3C40	500 (132)	500 (132)	410 (108) 500 (132)	310 (81.9) 500 (132)	(S-)DSHG-06-3H40	500 (132)	500 (132)	500 (132)	420 (111) 500 (132)
"5"	DSHG-06-3C5	500 (132)	500 (132)	425 (112)	350 (92.5)	DSHG-06-3H5	500 (132)	500 (132)	500 (132)	470 (124) 500 (132)
"6"	DSHG-06-3C6	475 (125)	390 (103)	300 (79.3)	230 (60.8)	DSHG-06-3H6	500 (132)	500 (132)	500 (132)	420 (111) 500 (132)
"60"	(S-)DSHG-06-3C60	475 (125)	420 (111)	340 (89.8)	280 (74.0)	(S-)DSHG-06-3H60	500 (132)	500 (132)	500 (132)	420 (111) 500 (132)
"7"	DSHG-06-3C7	500 (132)	500 (132)	450 (119)	360 (95.1)	DSHG-06-3H7	500 (132)	500 (132)	500 (132)	500 (132)
"9"	DSHG-06-3C9	500 (132)	500 (132)	450 (119) 500 (132)	360 (95.1) 500 (132)	DSHG-06-3H9	500 (132)	500 (132)	500 (132)	500 (132)
"10"	(S-)DSHG-06-3C10	500 (132)	500 (132)	410 (108) 500 (132)	310 (81.9) 500 (132)	(S-)DSHG-06-3H10	500 (132)	500 (132)	500 (132)	460 (122) 500 (132)
"11"	DSHG-06-3C11	500 (132)	500 (132)	410 (108) 500 (132)	310 (81.9) 500 (132)	DSHG-06-3H11	500 (132)	500 (132)	500 (132)	460 (122) 500 (132)
"12"	(S-)DSHG-06-3C12	500 (132)	500 (132)	410 (108) 500 (132)	310 (81.9) 500 (132)	(S-)DSHG-06-3H12	500 (132)	500 (132)	500 (132)	460 (122) 500 (132)

● Two Positions

Spool Type	No-Spring					Spring Offset				
	Graphic Symbol	Maximum Flow L/min (U.S.GPM)				Graphic Symbol	Maximum Flow L/min (U.S.GPM)			
	Model Numbers	10 MPa (1450 PSI)	16 MPa (2320 PSI)	25 MPa (3630 PSI)	31.5 MPa (4570 PSI)	Model Numbers	10 MPa (1450 PSI)	16 MPa (2320 PSI)	25 MPa (3630 PSI)	31.5 MPa (4570 PSI)
"2"	(S-)DSHG-06-2N2	500 (132)	500 (132)	500 (132)	500 (132)	(S-)DSHG-06-2B2	500 (132)	500 (132)	500 (132)	500 (132)
"3"	DSHG-06-2N3	500 (132)	500 (132)	500 (132)	500 (132)	DSHG-06-2B3	500 (132)	500 (132)	500 (132)	500 (132)
"4"	(S-)DSHG-06-2N4	500 (132)	500 (132)	500 (132)	500 (132)	(S-)DSHG-06-2B4	500 (132)	500 (132)	500 (132)	500 (132)
"40"	(S-)DSHG-06-2N40	500 (132)	500 (132)	500 (132)	500 (132)	(S-)DSHG-06-2B40	500 (132)	500 (132)	500 (132)	500 (132)
"7"	DSHG-06-2N7	500 (132)	500 (132)	500 (132)	500 (132)	DSHG-06-2B7	500 (132)	500 (132)	500 (132)	500 (132)

Notes: 1. The relation between max. flow and pilot pressure in the table above is as shown below.

(Example)

Maximum flow rate is constant regardless of pilot pressure. Pilot Pressure more than 0.8 MPa (120 PSI). In case pressure centred models, pilot pressure is more than 1 MPa (150 PSI).

500 (132)	410 (108)
	500 (132)

Pilot Pressure at 0.8 MPa (120 PSI). In case pressure centred models, pilot pressure is more than 1 MPa (150 PSI)

Pilot Pressure at 1.5 MPa (220 PSI).

2. Max. flow in the table above represents the value in the flow condition of P → A → B → T (or P → B → A → T) as shown in the circuit diagram right. In case the valve is used in the condition that either A or B port is blocked, the maximum flow differs according to a hydraulic circuit, therefore, please consult us for details.

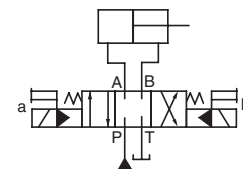

■ List of Spool Functions and Maximum Flow (DSHG-010/S-DSHG-10)

● Three Positions

Spool Type	Spring Centred					Pressure Centred					
	Graphic Symbol	Maximum Flow L/min (U.S.GPM)				Graphic Symbol	Maximum Flow L/min (U.S.GPM)				
	Model Numbers	10 MPa (1450 PSI)	16 MPa (2320 PSI)	25 MPa (3630 PSI)	31.5 MPa (4570 PSI)	Model Numbers	10 MPa (1450 PSI)	16 MPa (2320 PSI)	25 MPa (3630 PSI)	31.5 MPa (4570 PSI)	
"2"		(S-)DSHG-10-3C2	1100(291)	1100(291)	950(251) 1100(291)	750(198) 1100(291)	(S-)DSHG-10-3H2	1100(291)	1100(291)	1100(291)	970(256) 1100(291)
"3"		DSHG-10-3C3	1100(291)	1100(291)	1060(280)	895(236)	DSHG-10-3H3	1100(291)	1100(291)	1100(291)	1050(277) 1100(291)
"4"		(S-)DSHG-10-3C4	1100(291)	1100(291)	950(251) 1100(291)	750(198) 1100(291)	(S-)DSHG-10-3H4	1100(291)	1100(291)	1100(291)	970(256) 1100(291)
"40"		(S-)DSHG-10-3C40	1100(291)	1100(291)	950(251) 1100(291)	750(198) 1100(291)	(S-)DSHG-10-3H40	1100(291)	1100(291)	1100(291)	970(256) 1100(291)
"5"		DSHG-10-3C5	1100(291)	1100(291)	980(259)	850(225)	DSHG-10-3H5	1100(291)	1100(291)	1100(291)	1000(264) 1100(291)
"6"		DSHG-10-3C6	1050(277)	880(232)	700(185)	570(151)	DSHG-10-3H6	1100(291)	1100(291)	1100(291)	970(256) 1100(291)
"60"		(S-)DSHG-10-3C60	1050(277)	940(248)	785(207)	680(180)	(S-)DSHG-10-3H60	1100(291)	1100(291)	1100(291)	970(256) 1100(291)
"7"		DSHG-10-3C7	1100(291)	1100(291)	1040(275) 1100(291)	870(230) 1100(291)	DSHG-10-3H7	1100(291)	1100(291)	1100(291)	1100(291)
"9"		DSHG-10-3C9	1100(291)	1100(291)	1040(275)	870(230)	DSHG-10-3H9	1100(291)	1100(291)	1100(291)	1100(291)
"10"		(S-)DSHG-10-3C10	1100(291)	1100(291)	950(251) 1100(291)	750(198) 1100(291)	(S-)DSHG-10-3H10	1100(291)	1100(291)	1100(291)	1060(280) 1100(291)
"11"		DSHG-10-3C11	1100(291)	1100(291)	950(251) 1100(291)	750(198) 1100(291)	DSHG-10-3H11	1100(291)	1100(291)	1100(291)	1060(280) 1100(291)
"12"		(S-)DSHG-10-3C12	1100(291)	1100(291)	950(251) 1100(291)	750(198) 1100(291)	(S-)DSHG-10-3H12	1100(291)	1100(291)	1100(291)	1060(280) 1100(291)

● Two Positions

Spool Type	No-Spring					Spring Offset					
	Graphic Symbol	Maximum Flow L/min (U.S.GPM)				Graphic Symbol	Maximum Flow L/min (U.S.GPM)				
	Model Numbers	10 MPa (1450 PSI)	16 MPa (2320 PSI)	25 MPa (3630 PSI)	31.5 MPa (4570 PSI)	Model Numbers	10 MPa (1450 PSI)	16 MPa (2320 PSI)	25 MPa (3630 PSI)	31.5 MPa (4570 PSI)	
"2"		(S-)DSHG-10-2N2	1100(291)	1100(291)	1100(291)	1100(291)	(S-)DSHG-10-2B2	1100(291)	1100(291)	1100(291)	1100(291)
"3"		DSHG-10-2N3	1100(291)	1100(291)	1100(291)	1100(291)	DSHG-10-2B3	1100(291)	1100(291)	1100(291)	1100(291)
"4"		(S-)DSHG-10-2N4	1100(291)	1100(291)	1100(291)	1100(291)	(S-)DSHG-10-2B4	1100(291)	1100(291)	1100(291)	1100(291)
"40"		(S-)DSHG-10-2N40	1100(291)	1100(291)	1100(291)	1100(291)	(S-)DSHG-10-2B40	1100(291)	1100(291)	1100(291)	1100(291)
"7"		DSHG-10-2N7	1100(291)	1100(291)	1100(291)	1100(291)	DSHG-10-2B7	1100(291)	1100(291)	1100(291)	1100(291)

Notes) 1. The relation between max. flow and pilot pressure in the table above is as shown below.

(Example)

Maximum flow rate is constant regardless of pilot pressure.
Pilot Pressure more than 1 MPa (150 PSI).

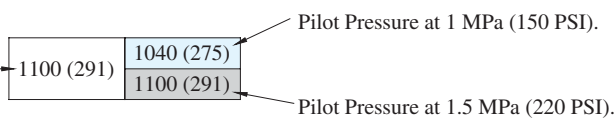

2. Max. flow in the table above represents the value in the flow condition of P → A → B → T (or P → B → A → T) as shown in the circuit diagram right.
In case the valve is used in the condition that either A or B port is blocked, the maximum flow differs according to a hydraulic circuit, therefore, please consult us for details.

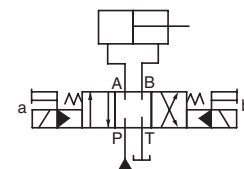

Reverse Mounting of Solenoid.

In spring offset type, it is a standard configuration that the solenoid is mounted onto the valve in the SOL b position (side). However, in this particular spool-spring arrangement, the mounting of the solenoid onto the valve in the reverse position - SOL a side - is also available. The graphic symbol for this reverse mounting is as shown below. As for the valve type 2B*A and 2B*B, please refer to the explanation under the heading of "Valves Using Neutral Position and Side Position" given below.

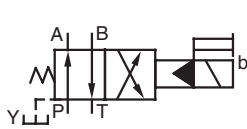

Standard Mtg. of Solenoid

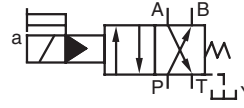
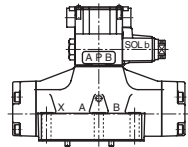

Reverse Mtg. of Solenoid ("L")

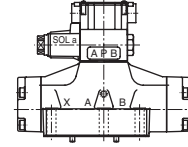

Valves Using Neutral Position and Side Position. (Special Two position Valve)

Besides the use of the standard 2-position valves aforementioned in the "List of Standard Models and Maximum Flow", the 3-position valves also can be used as the 2-position valves using the two of their three positions. In this case, there are two kinds of the valve available. One is the valve using the neutral position and SOL a position (2B*A) and another is the valve using the neutral position and SOL b position (2B*B).

(Example) In case of Spool Type "2"

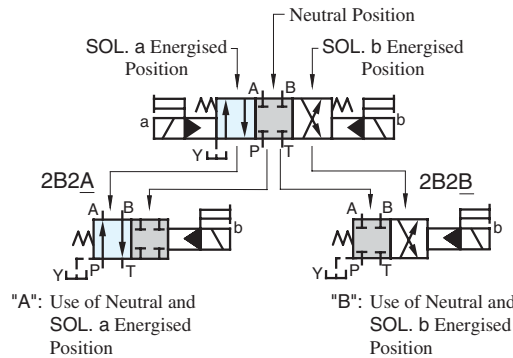

Model Numbers	Graphic Symbols	
	Standard Mtg.	Reverse Mtg. Type
04 DSHG-06-2B*A 10		
(S-)DSHG-*-2B2A		
DSHG-*-2B3A		
(S-)DSHG-*-2B4A		
(S-)DSHG-*-2B40A		
DSHG-*-2B5A		
DSHG-*-2B6A		
(S-)DSHG-*-2B60A		
DSHG-*-2B7A		
DSHG-*-2B9A		
(S-)DSHG-*-2B10A		
DSHG-*-2B11A		
(S-)DSHG-*-2B12A		

Model Numbers	Graphic Symbols	
	Standard Mtg.	Reverse Mtg. Type
04 DSHG-06-2B*B 10		
(S-)DSHG-*-2B2B		
DSHG-*-2B3B		
(S-)DSHG-*-2B4B		
(S-)DSHG-*-2B40B		
DSHG-*-2B5B		
DSHG-*-2B6B		
(S-)DSHG-*-2B60B		
DSHG-*-2B7B		
DSHG-*-2B9B		
(S-)DSHG-*-2B10B		
DSHG-*-2B11B		
(S-)DSHG-*-2B12B		

Model Numbers	Graphic Symbols
	Standard Mtg.
04 DSHG-06-2N*A 10	
(S-)DSHG-*-2N2A	
DSHG-*-2N3A	
(S-)DSHG-*-2N4A	
(S-)DSHG-*-2N40A	
DSHG-*-2N5A	
DSHG-*-2N6A	
(S-)DSHG-*-2N60A	
DSHG-*-2N7A	
DSHG-*-2N9A	
(S-)DSHG-*-2N10A	
DSHG-*-2N11A	
(S-)DSHG-*-2N12A	

■ Pressure Drop

Pressure drop curves based on viscosity of 35 mm²/s (164 SSU) and specific gravity of 0.850.

● DSHG-01

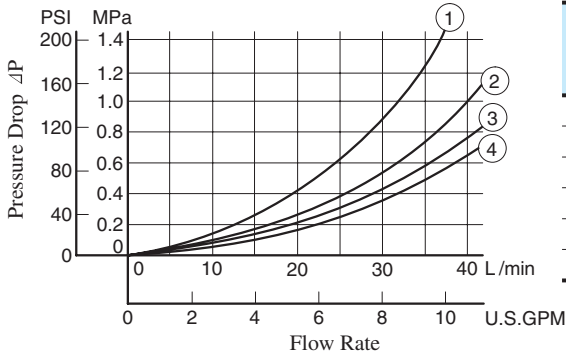

● DSHG-01

Spool Type	Pressure Drop Curve Numbers					Spool Type	Pressure Drop Curve Numbers				
	P→A	B→T	P→B	A→T	P→T		P→A	B→T	P→B	A→T	P→T
2	③	②	③	②	—	7	③	②	③	②	—
3	④	②	④	②	②	9	④	②	④	②	—
4	③	②	③	②	—	10	③	②	③	②	—
40	③	②	③	②	—	11	③	②	③	②	—
5	③	②	③	②	①	12	③	②	③	②	—
60	③	②	③	②	①						

● DSHG-03

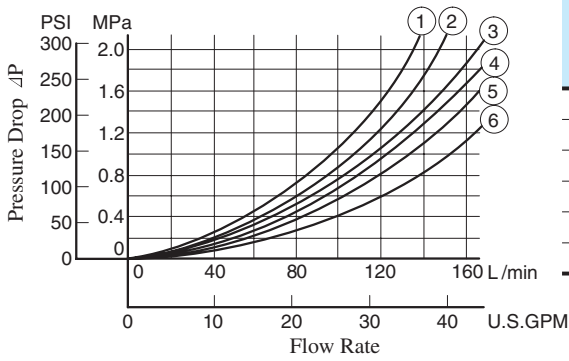

● DSHG-03

Spool Type	Pressure Drop Curve Numbers					Spool Type	Pressure Drop Curve Numbers				
	P→A	B→T	P→B	A→T	P→T		P→A	B→T	P→B	A→T	P→T
2	③	③	④	④	—	7	③	③	④	④	—
3	⑤	⑤	⑤	⑥	④	9	⑥	③	⑥	④	—
4	③	⑤	④	⑥	—	10	③	⑤	④	④	—
40	③	③	④	④	—	11	⑥	③	④	④	—
5	⑥	③	④	⑥	②	12	③	③	④	⑥	—
60	③	③	④	④	①						

● DSHG-04, S-DSHG-04

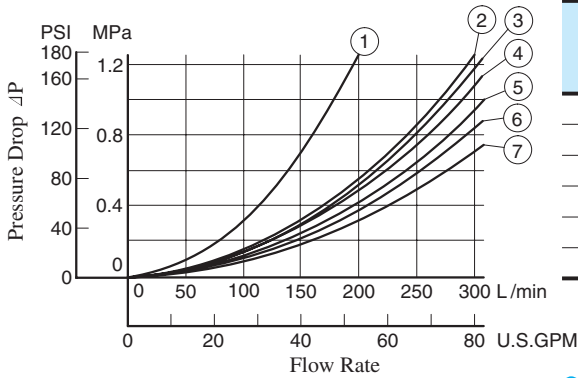

● DSHG-04

Spool Type	Pressure Drop Curve Numbers					Spool Type	Pressure Drop Curve Numbers				
	P→A	B→T	P→B	A→T	P→T		P→A	B→T	P→B	A→T	P→T
2	⑤	④	⑤	⑥	—	60	⑦	⑤	⑦	⑦	②
3	⑤	③	⑤	⑤	⑦	7	⑤	④	⑤	⑥	—
4	⑤	③	⑤	⑤	—	9	⑤	④	⑤	⑥	—
40	⑤	④	⑤	⑥	—	10	⑤	②	⑤	⑥	—
5	⑦	④	⑤	⑤	⑤	11	⑥	④	⑤	⑥	—
6	⑤	③	⑤	⑥	①	12	⑤	④	⑤	⑤	—

● S-DSHG-04

Spool Type	Pressure Drop Curve Numbers					Spool Type	Pressure Drop Curve Numbers				
	P→A	B→T	P→B	A→T	P→T		P→A	B→T	P→B	A→T	P→T
2	②	②	②	④	—	60	⑥	④	⑥	⑦	②
4	②	③	②	⑤	—	10	②	②	②	④	—
40	②	④	②	⑥	—	12	②	②	②	⑤	—

● DSHG-06, S-DSHG-06

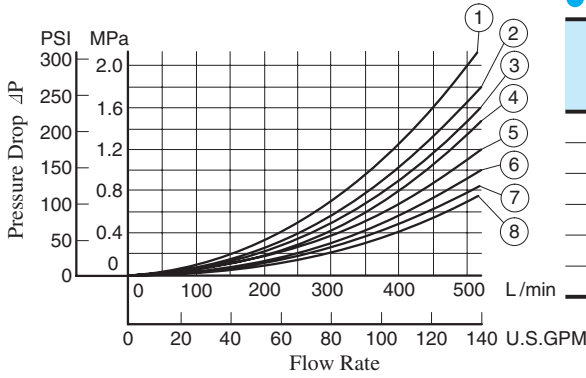

● DSHG-06

Spool Type	Pressure Drop Curve Numbers					Spool Type	Pressure Drop Curve Numbers				
	P→A	B→T	P→B	A→T	P→T		P→A	B→T	P→B	A→T	P→T
2	⑧	⑤	⑧	⑦	—	60	⑥	⑤	⑥	⑦	①
3	⑥	④	⑥	⑦	④	7	⑥	④	⑥	⑦	—
4	⑧	⑤	⑧	⑦	—	9	⑥	⑤	⑥	⑦	—
40	⑧	⑤	⑧	⑦	—	10	⑧	⑤	⑧	⑦	—
5	⑧	④	⑤	⑦	①	11	⑧	④	⑤	⑦	—
6	⑤	③	⑤	④	①	12	⑧	⑤	⑧	⑦	—

● S-DSHG-06

Spool Type	Pressure Drop Curve Numbers					Spool Type	Pressure Drop Curve Numbers				
	P→A	B→T	P→B	A→T	P→T		P→A	B→T	P→B	A→T	P→T
2	⑥	①	⑥	②	—	60	⑥	②	⑥	③	①
4	⑥	②	⑥	②	—	10	⑧	⑤	⑧	⑦	—
40	⑧	⑤	⑧	⑦	—	12	⑧	⑤	⑧	⑦	—

● DSHG-10, S-DSHG-10

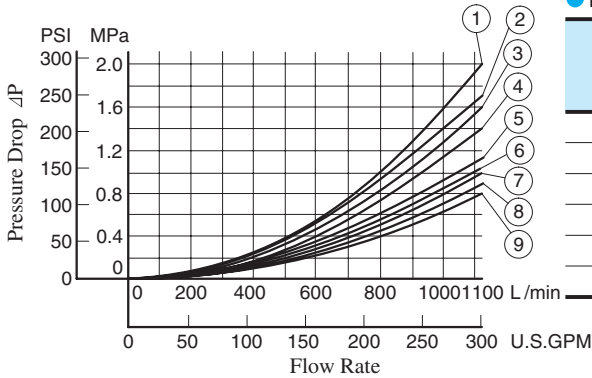

● DSHG-10

Spool Type	Pressure Drop Curve Numbers					Spool Type	Pressure Drop Curve Numbers				
	P→A	B→T	P→B	A→T	P→T		P→A	B→T	P→B	A→T	P→T
2	⑨	⑥	⑨	⑧	—	60	⑧	⑤	⑧	⑤	③
3	⑦	⑥	⑦	⑦	⑤	7	⑦	⑥	⑦	⑦	—
4	⑨	⑥	⑨	⑥	—	9	⑦	⑥	⑦	⑧	—
40	⑨	⑥	⑨	⑧	—	10	⑨	⑤	⑨	⑧	—
5	⑨	⑥	⑧	⑥	①	11	⑨	⑥	⑧	⑦	—
6	⑤	③	⑤	②	②	12	⑨	⑦	⑨	⑥	—

● S-DSHG-10

Spool Type	Pressure Drop Curve Numbers					Spool Type	Pressure Drop Curve Numbers				
	P→A	B→T	P→B	A→T	P→T		P→A	B→T	P→B	A→T	P→T
2	⑧	③	⑧	④	—	60	⑧	④	⑧	④	②
4	⑧	⑤	⑧	⑥	—	10	⑨	⑤	⑨	⑧	—
40	⑨	⑥	⑨	⑧	—	12	⑨	⑦	⑨	⑥	—

● For any other viscosity, multiply the factors in the table below.

Viscosity	mm ² /s	15	20	30	40	50	60	70	80	90	100
		SSU	77	98	141	186	232	278	324	371	417
	Factor	0.81	0.87	0.96	1.03	1.09	1.14	1.19	1.23	1.27	1.30

● For any other specific gravity (G'), the pressure drop (ΔP') may be obtained from the formula right.

$$\Delta P' = \Delta P(G'/0.850)$$

Typical Changeover Time

Changeover time varies according to oil viscosity, spool type and hydraulic circuit.

Test Conditions

Coil Type : D*(Models with DC solenoids)

Voltage : Rated Voltage

Oil Viscosity : 35 mm²/s (164 SSU)

DSHG-04

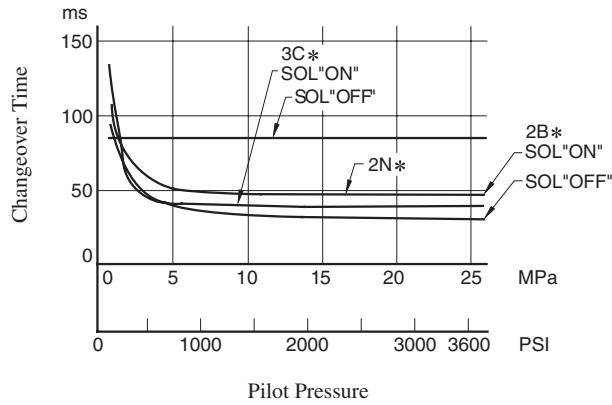

DSHG-10

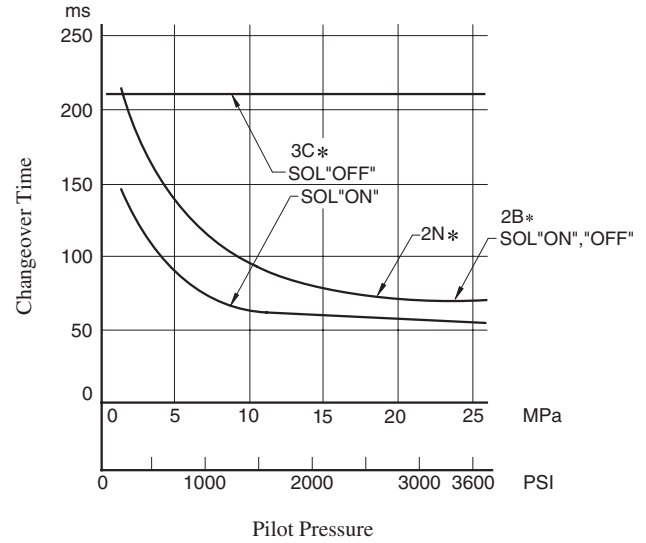

DSHG-06

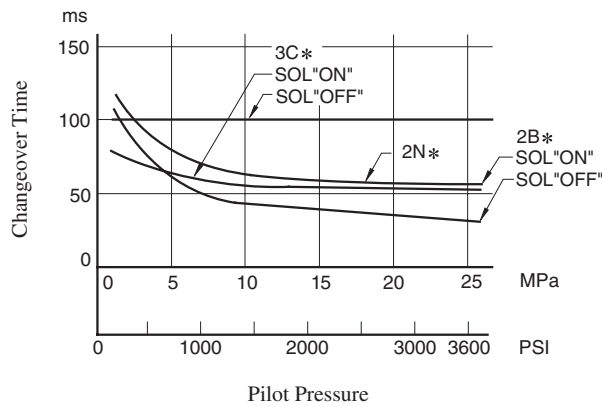

Terminal Box type: DSHG-01-***-*-14/1490

Mounting surface: ISO 4401-AB-03-4-A

Internal Pilot - Internal Drain

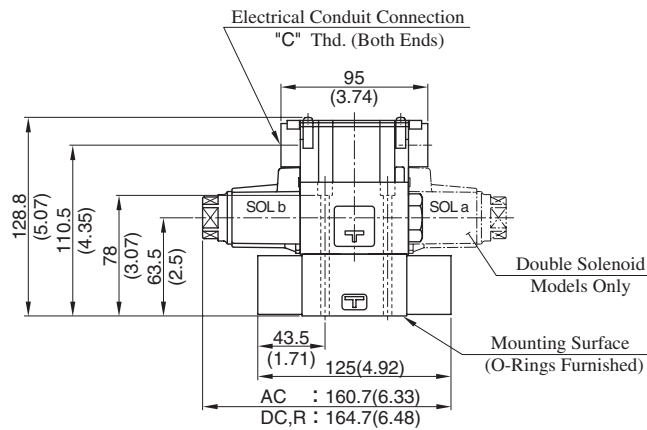
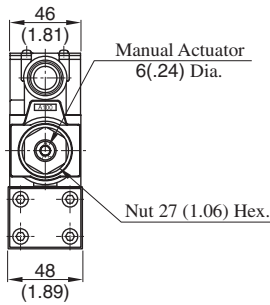
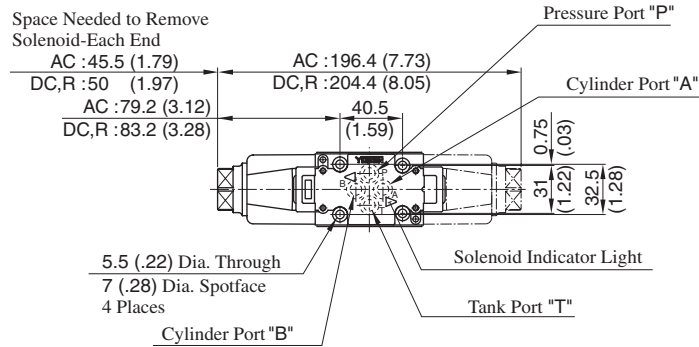

Model Numbers	"C" Thd.	"D" Thd.
DSHG-01-***-*-14	G 1/2	Rc 1/4
DSHG-01-***-*-1490	1/2 NPT	1/4 NPT

DIMENSIONS IN MILLIMETRES (INCHES)

- External Pilot - External Drain
- External Pilot - Internal Drain
- Internal Pilot - External Drain

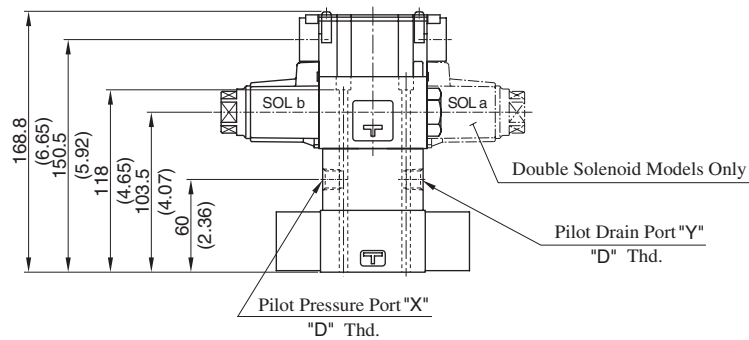

For other dimensions, refer to "Internal Pilot Internal Drain".

Mounting surface: ISO 4401-AB-03-4-A

■ Plug-in Connector Type: DSHG-01-***-N₁-14/1480/1490

● Internal Pilot-Internal Drain

The position of the Plug-in connector can be changed as illustrated below by loosening the lock nut. After completion of the change, be sure to tighten the lock nut with the torque as specified below.

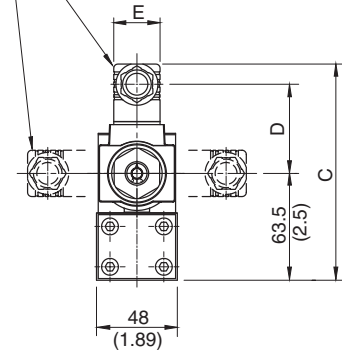

Lock Nut
Tightening Torque:
10.3 - 11.3 Nm (91-100 IN.lbs.)

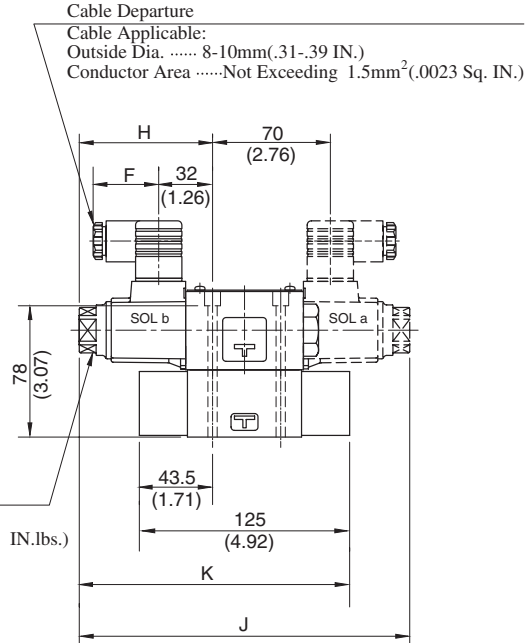

Cable Departure
Cable Applicable:
Outside Dia. 8-10mm(.31-.39 IN.)
Conductor AreaNot Exceeding 1.5mm²(.0023 Sq. IN.)

DIMENSIONS IN
MILLIMETRES (INCHES)

- External Pilot-External Drain
- External Pilot-Internal Drain
- Internal Pilot-External Drain

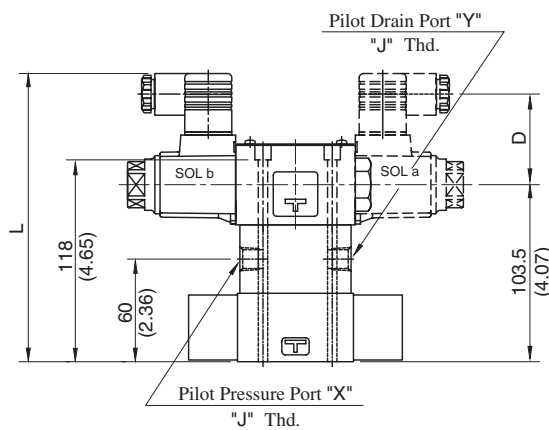

Model Numbers	"J" Thd.
DSHG-01-***-N*-14	Rc 1/4
DSHG-01-***-N*-1480	1/4 BSP.F
DSHG-01-***-N*-1490	1/4 NPT

Model Numbers	Dimensions mm (Inches)							
	C	D	E	F	H	J	K	L
DSHG-01-***-A*-N/N1	128.5 (5.06)	53 (2.09)	27.5 (1.08)	39 (1.54)	79.2 (3.12)	196.4 (7.73)	160.7 (6.33)	168.5 (6.63)
DSHG-01-***-D*-N/N1	139.5 (5.49)	64 (2.52)	27.5 (1.08)	39 (1.54)	83.2 (3.28)	204.4 (8.05)	164.7 (6.48)	179.5 (7.07)
DSHG-01-***-R*-N	142.5 (5.61)	57.2 (2.25)	34 (1.34)	53 (2.09)				182.5 (7.19)

● For other dimensions, refer to "Terminal Box Type".

■ Terminal Box Type: DSHG-03-***-*-14/1490

Mounting surface: ISO 4401-AC-05-4-A
(The pilot and drain ports in accordance with the ISO original draft)

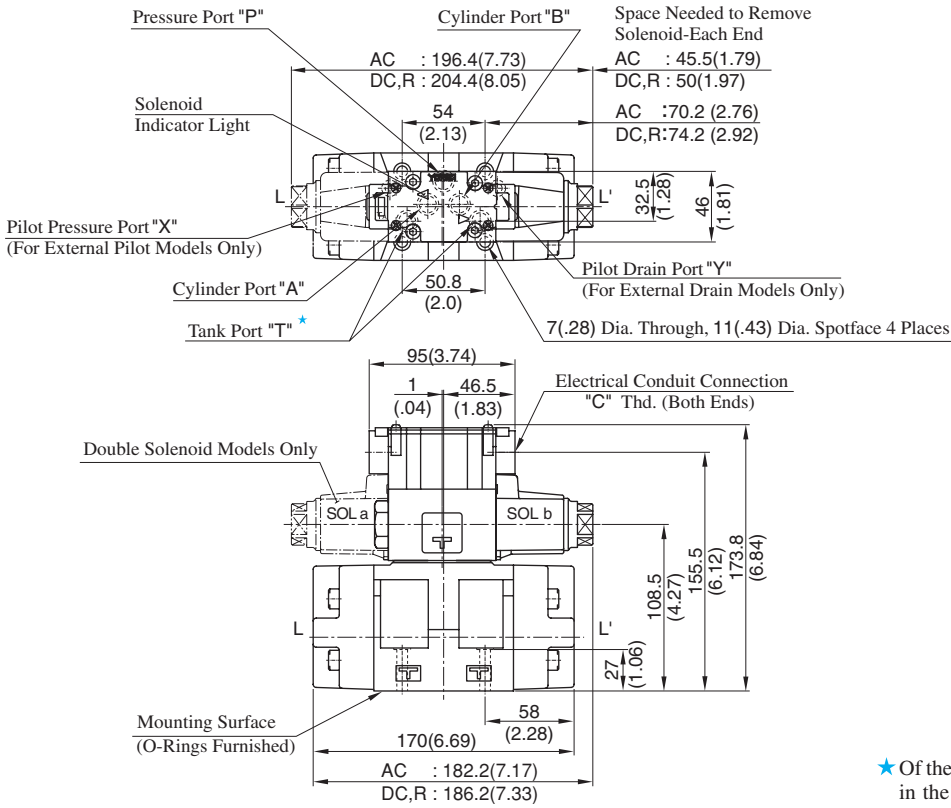

Model Numbers	"C" Thd.
DSHG-03-***-*-14	G 1/2
DSHG-03-***-*-1490	1/2 NPT

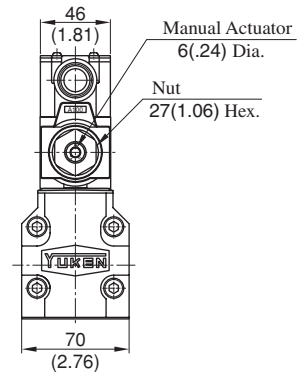

★ Of the two of tank port "T", the tank port in the left side is normally used in our standard sub-plate, though, either side of the tank port "T" can be used without problem.

DIMENSIONS IN MILLIMETRES (INCHES)

■ Plug-in Connector Type: DSHG-03-***-*-N₁-14/1490

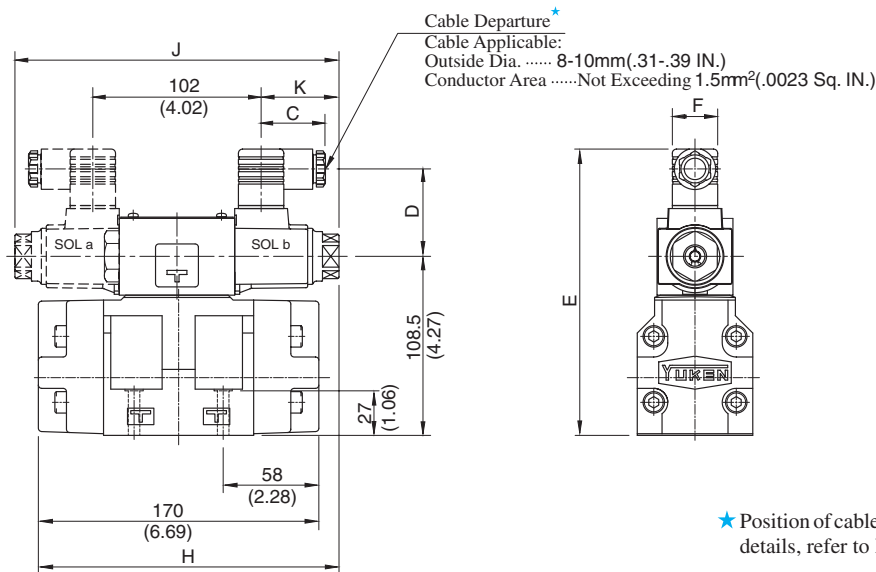

★ Position of cable departure can be changed. For details, refer to DSHG-01 valve on page 16.

Model Numbers	Dimensions mm (Inches)						
	C	D	E	F	H	J	K
DSHG-03-***-*-A*-N/N1	39 (1.54)	53 (2.09)	173.5 (6.83)	27.5 (1.08)	182.2 (7.17)	196.4 (7.73)	47.2 (1.86)
DSHG-03-***-*-D*-N/N1	39 (1.54)	64 (2.52)	184.5 (7.26)	27.5 (1.08)	186.2 (7.33)	204.4 (8.05)	51.2 (2.02)
DSHG-03-***-*-R*-N	53 (2.09)	57.2 (2.25)	187.5 (7.38)	34 (1.34)	186.2 (7.33)	204.4 (8.05)	51.2 (2.02)

• For other dimensions, refer to "Terminal Box Type".

Terminal Box Type: (S-)DSHG-04-***-*-52/5290

Mounting surface:
ISO 4401-AD-07-4-A

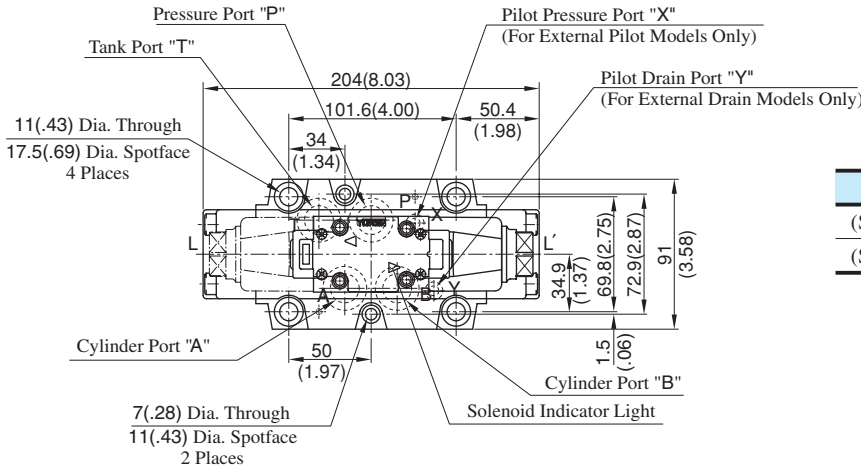

Model Numbers	"C" Thd.
(S-)DSHG-04-***-*-52	G 1/2
(S-)DSHG-04-***-*-5290	1/2 NPT

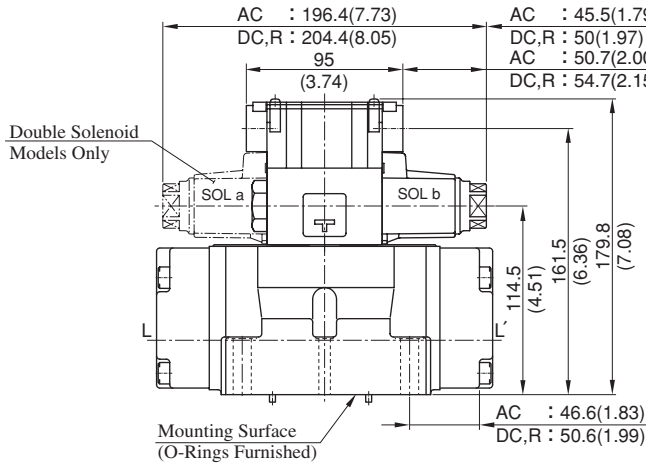

Space Needed to Remove
Solenoid-Each End

Electrical Conduit Connection
"C" Thd. (Both Ends)

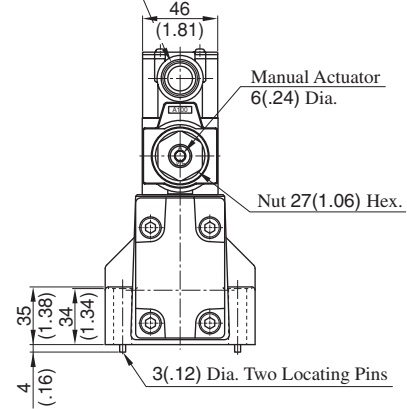

DIMENSIONS IN
MILLIMETRES (INCHES)

Plug-in Connector Type: (S-)DSHG-04-***-*-N₁-52/5290

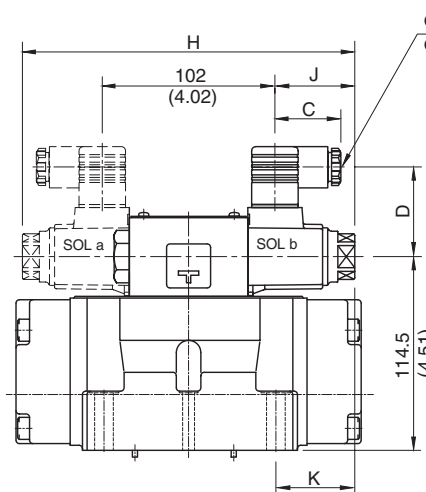

Cable Departure ★

Cable Applicable:

Outside Dia. 8-10 mm(.31 - .39 IN.)

Conductor Area ... Not Exceeding 1.5 m²(.0023 Sq. IN.)

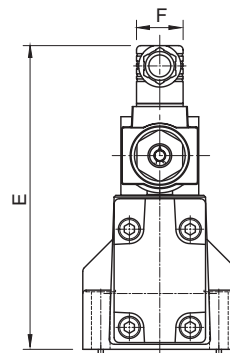

★ Position of cable
departure can be
changed. For details,
refer to DSHG-01
valve on [page 16](#).

Model Numbers	Dimensions mm (Inches)						
	C	D	E	F	H	J	K
(S-)DSHG-04-***-A*-N/N1	39 (1.54)	53 (2.09)	173.5 (6.83)	27.5 (1.08)	196.4 (7.73)	47.2 (1.86)	45.6 (1.80)
(S-)DSHG-04-***-D*-N/N1	39 (1.54)	64 (2.52)	184.5 (7.26)	27.5 (1.08)	204.4 (8.05)	51.2 (2.02)	49.6 (1.95)
(S-)DSHG-04-***-R*-N	53 (2.09)	57.2 (2.25)	187.6 (7.39)	34 (1.34)			

● For other dimensions, refer to "Terminal Box Type".

■ Terminal Box Type: (S-)DSHG-06-***-*-53/5390

Mounting surface:
ISO 4401-AE-08-4-A

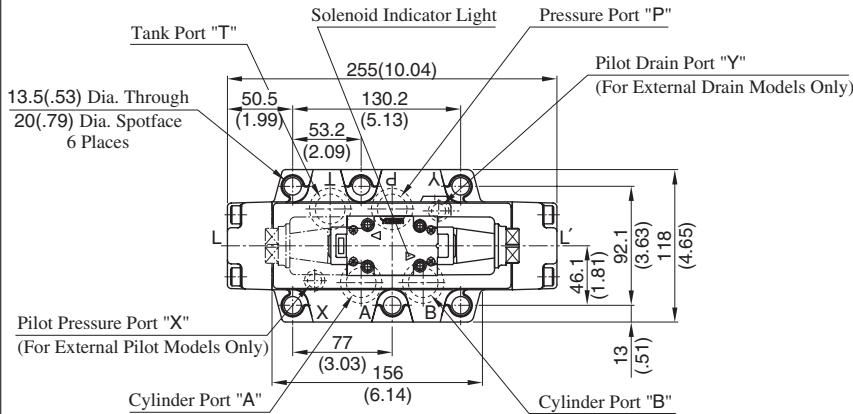

Model Numbers	"C" Thd.
(S-)DSHG-06-***-*-53	G 1/2
(S-)DSHG-06-***-*-5390	1/2 NPT

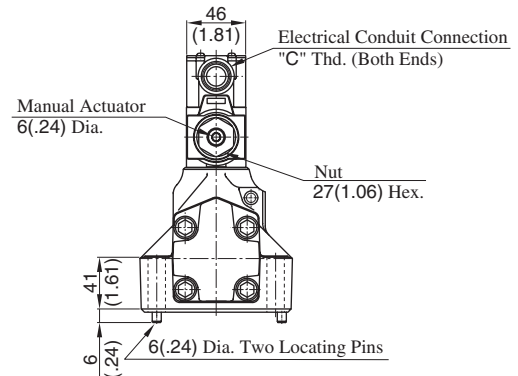
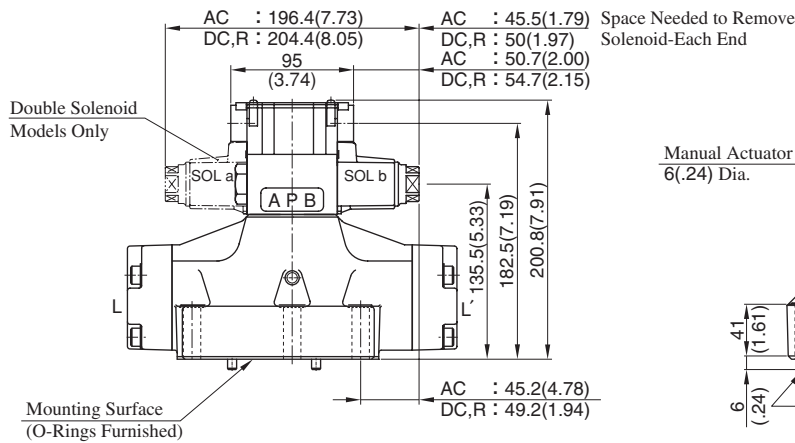

DIMENSIONS IN
MILLIMETRES (INCHES)

■ Plug-in Connector Type: (S-)DSHG-06-***-*-N₁-53/5390

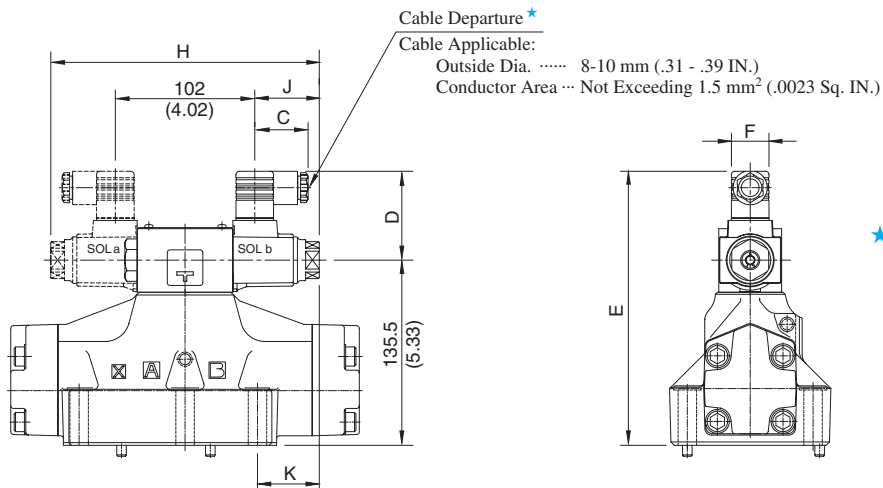

★ Position of cable departure can be changed. For details, refer to DSHG-01 valve on page 16.

Model Numbers	Dimensions mm (Inches)						
	C	D	E	F	H	J	K
(S-)DSHG-06-***-A*-N/N1	39 (1.54)	53 (2.09)	200.5 (7.95)	27.5 (1.08)	196.4 (7.73)	47.2 (1.86)	45.2 (1.78)
(S-)DSHG-06-***-D*-N/N1	39 (1.54)	64 (2.52)	211.5 (8.33)	27.5 (1.08)	204.4 (8.05)	51.2 (2.02)	49.2 (1.94)
(S-)DSHG-06-***-R*-N	53 (2.09)	57.2 (2.25)	214.5 (8.44)	34 (1.34)			

● For other dimensions, refer to "Terminal Box Type".

■ Terminal Box Type: (S-)DSHG-10-***-*-43/4390

Mounting surface:
ISO 4401-AF-10-4-A

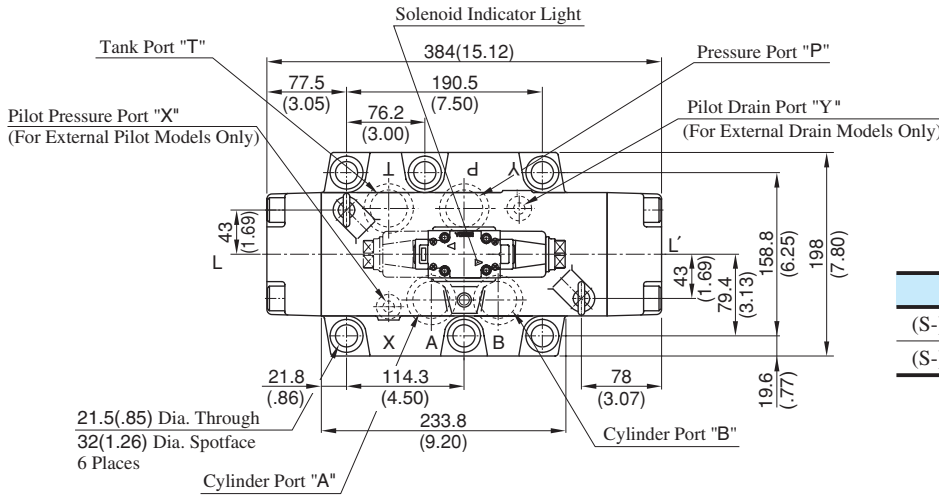

Model Numbers	"C" Thd.
(S-)DSHG-10-***-*-43	G 1/2
(S-)DSHG-10-***-*-4390	1/2 NPT

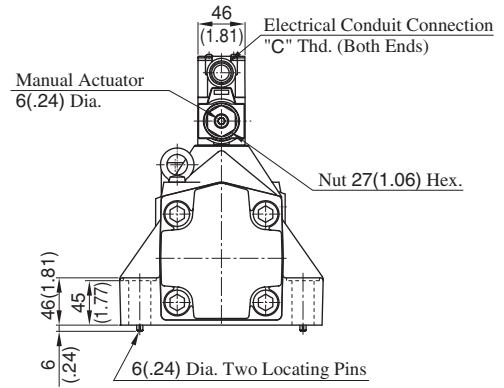
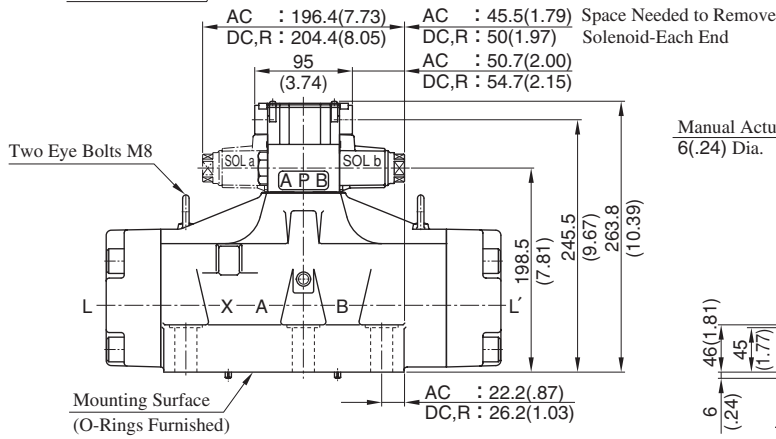

DIMENSIONS IN
MILLIMETRES (INCHES)

■ Plug-in Connector Type: (S-)DSHG-10-***-*-N₁-43/4390

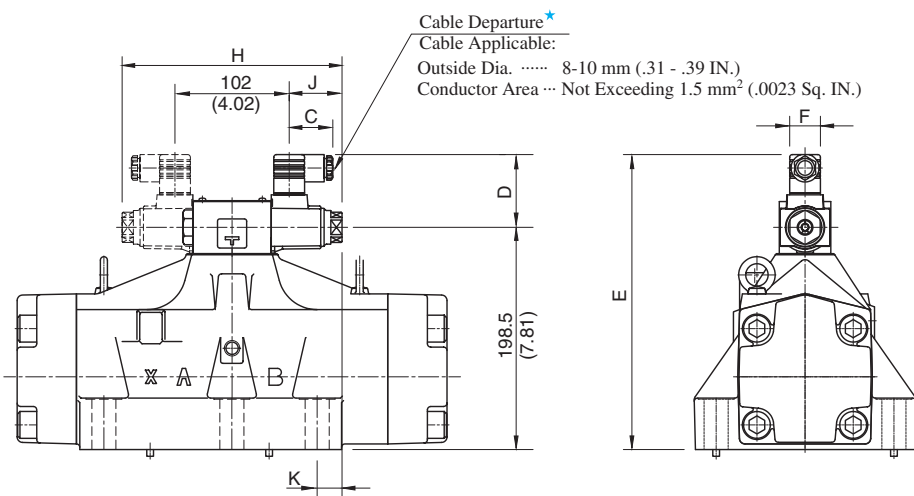

★ Position of cable departure can be changed. For details, refer to DSHG-01 valve on page 16.

Model Numbers	Dimensions mm (Inches)						
	C	D	E	F	H	J	K
(S-)DSHG-10-***-A*-N/N1	39 (1.54)	53 (2.09)	263.5 (10.37)	27.5 (1.08)	196.4 (7.73)	47.2 (1.86)	22.2 (.87)
(S-)DSHG-10-***-D*-N/N1	39 (1.54)	64 (2.52)	274.5 (10.81)	27.5 (1.08)	204.4 (8.05)	51.2 (2.02)	26.2 (1.03)
(S-)DSHG-10-***-R*-N	53 (2.09)	57.2 (2.25)	277.5 (10.93)	34 (1.34)			

● For other dimensions, refer to "Terminal Box Type".

Sub-plate

● DHGM-03Y-10/1080/1090

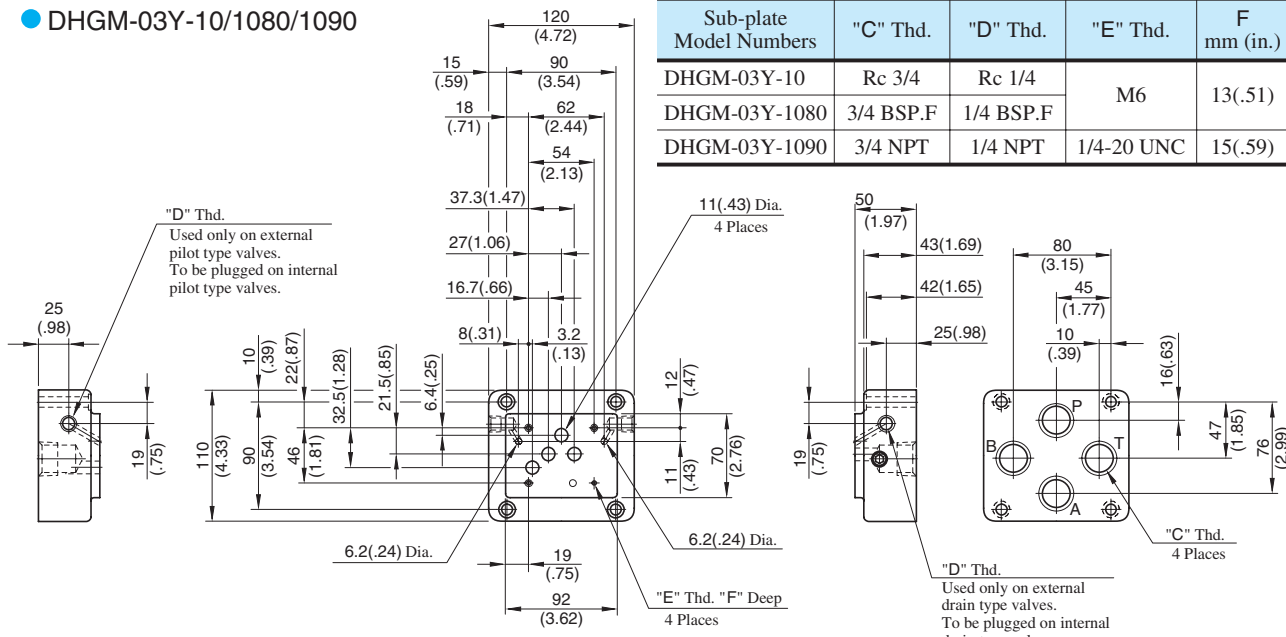

Sub-plate Model Numbers	"C" Thd.	"D" Thd.	"E" Thd.	F mm (in.)
DHGM-03Y-10	Rc 3/4	Rc 1/4	M6	13(.51)
DHGM-03Y-1080	3/4 BSP.F	1/4 BSP.F		
DHGM-03Y-1090	3/4 NPT	1/4 NPT	1/4-20 UNC	15(.59)

DIMENSIONS IN MILLIMETRES (INCHES)

● DHGM-04-04X-20/2080/2090

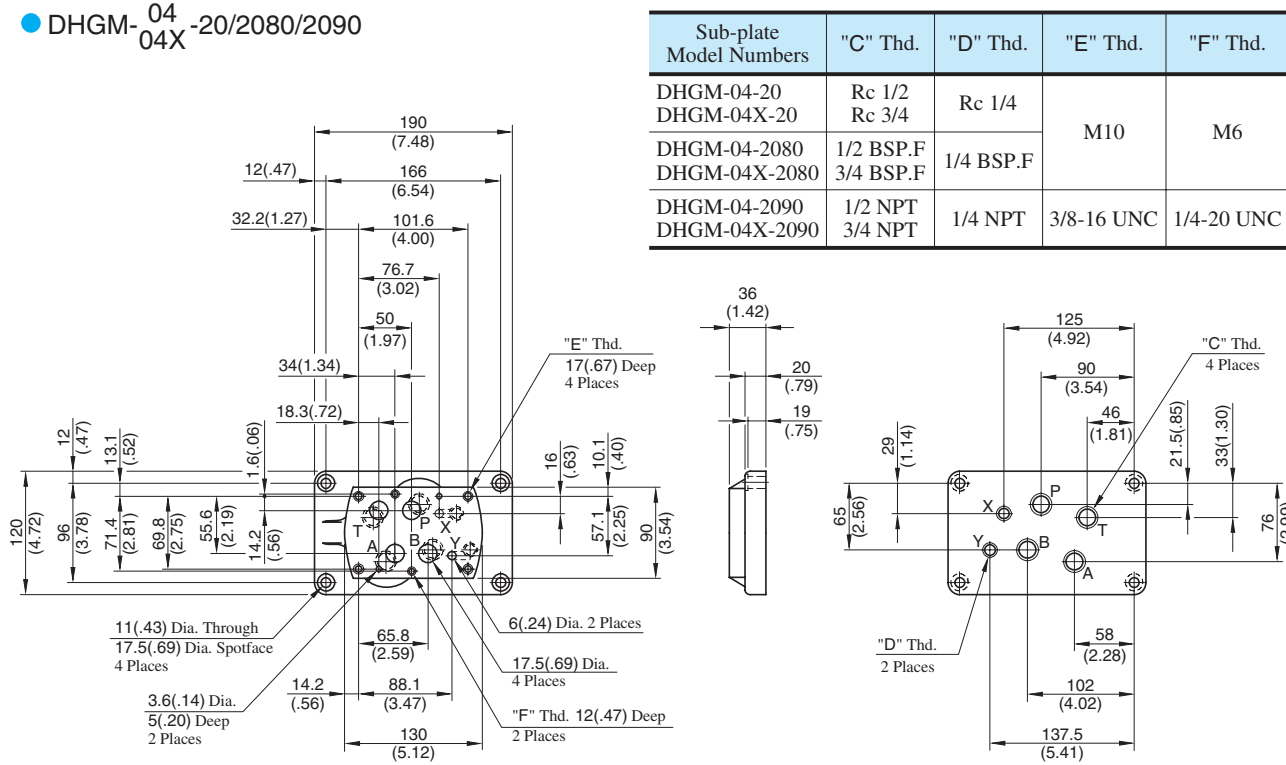

Sub-plate Model Numbers	"C" Thd.	"D" Thd.	"E" Thd.	"F" Thd.
DHGM-04-20	Rc 1/2	Rc 1/4	M10	M6
DHGM-04X-20	Rc 3/4			
DHGM-04-2080	1/2 BSP.F	1/4 BSP.F		
DHGM-04X-2080	3/4 BSP.F			
DHGM-04-2090	1/2 NPT	1/4 NPT	3/8-16 UNC	1/4-20 UNC
DHGM-04X-2090	3/4 NPT			

Valve Types		Pilot Pressure Port "X"	Port "Y"
Solenoid Controlled Pilot Operated Directional Valves		Used only on external pilot type valves. To be plugged on internal pilot type valves.	Used as drain port only on external drain type valves. To be plugged on internal drain type valves.
Pilot Operated Directional Valves	Spring Centred No-spring	Used	Used as pilot pressure port
	Spring Offset		Used as pilot drain port
Manually Operated Directional Valves		Not used (plug is not required)	Used as drain port

Sub-plate

● DHGM-06-50/5090
06X

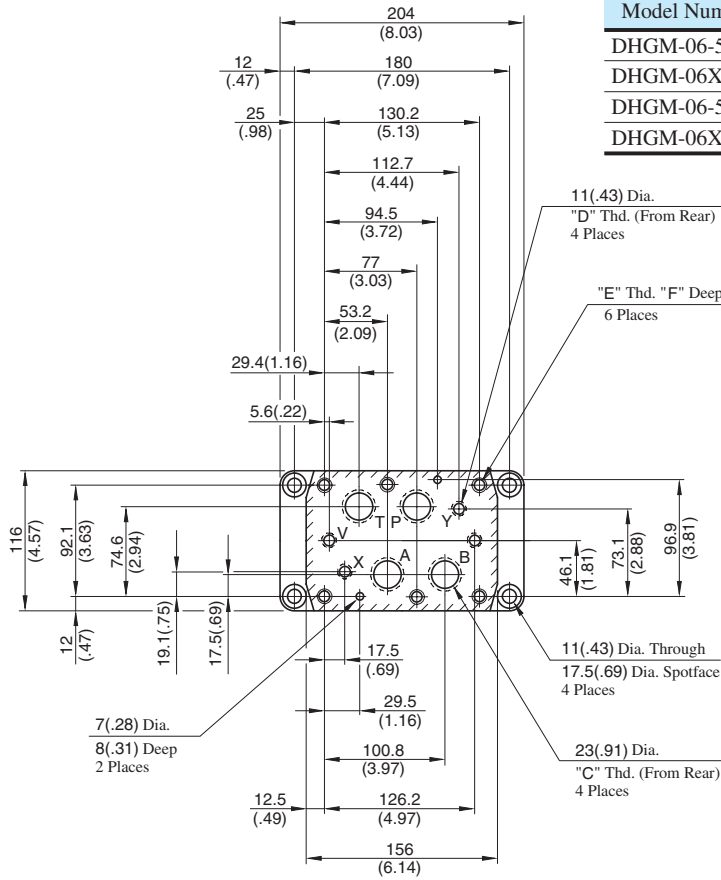

Sub-plate Model Numbers	"C" Thd.	"D" Thd.	"E" Thd.	F mm (in.)
DHGM-06-50	Rc 3/4	Rc 1/4	M12	24 (.94)
DHGM-06X-50	Rc 1			
DHGM-06-5090	3/4 NPT	1/4 NPT	1/2-13 UNC	26 (1.02)
DHGM-06X-5090	1 NPT			

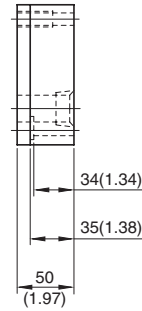

DIMENSIONS IN MILLIMETRES (INCHES)

● DHGM-06-5080
06X

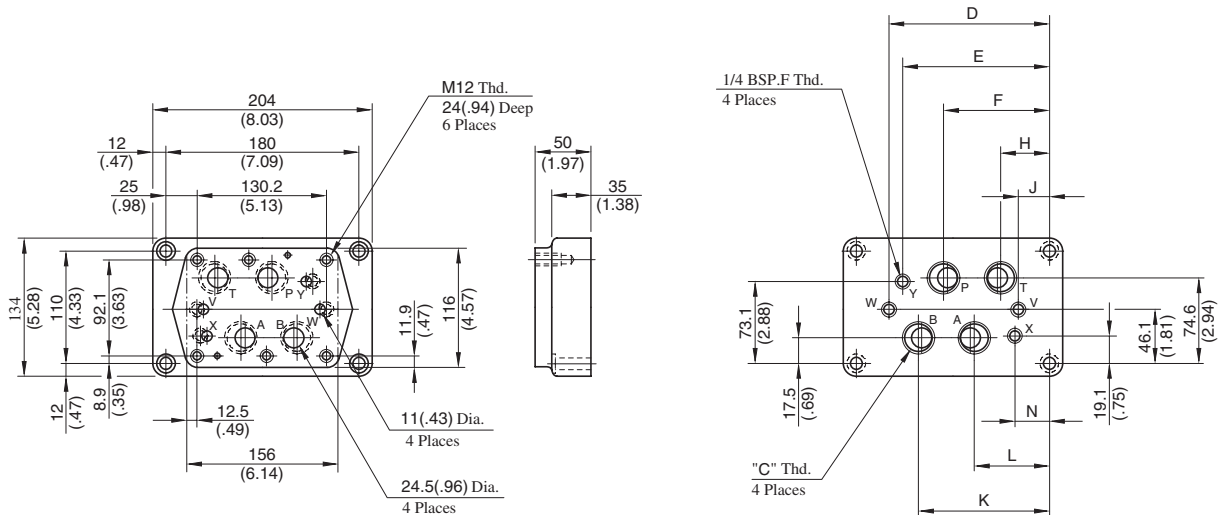

Sub-plate Model Numbers	"C" Thd.	Dimensions mm (Inches)							
		D	E	F	H	J	K	L	N
DHGM-06-5080	3/4 BSP.F	151.2 (5.95)	137.7 (5.42)	102 (4.02)	54.4 (2.14)	30.6 (1.20)	125.8 (4.95)	78.2 (3.08)	42.5 (1.67)
DHGM-06X-5080	1 BSP.F	155.2 (6.11)	148 (5.83)	106 (4.17)	50 (1.97)	25 (.98)	130 (5.12)	74 (2.91)	32 (1.26)

For other dimensions, refer to "DHGM-06*-50/5090" above.

* For Uses of Port "X", "Y", "V", "W", refer to DHGM-10* on the following page.

Sub-plate

● DHGM-10-40/4080/4090
10X

DIMENSIONS IN MILLIMETRES (INCHES)

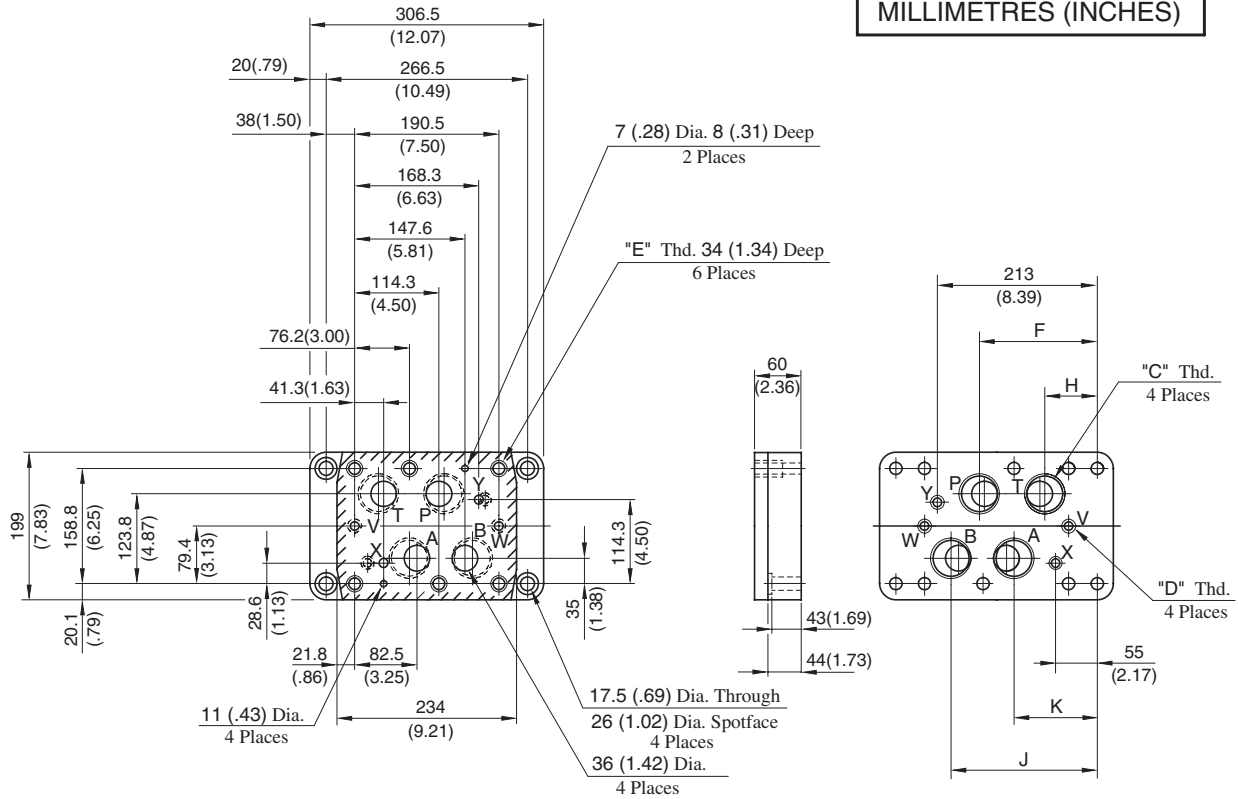

Sub-plate Model Numbers	"C" Thd.	"D" Thd.	"E" Thd.	Dimensions mm (Inches)			
				F	H	J	K
DHGM-10-40	Rc 1-1/4	Rc 3/8	M20				
DHGM-10-4080	1-1/4 BSP.F	3/8 BSP.F	M20	152 (5.98)	79 (3.11)	185.5 (7.30)	120.5 (4.74)
DHGM-10-4090	1-1/4 NPT	3/8 NPT	3/4-10 UNC				
DHGM-10X-40	Rc 1-1/2	Rc 3/8	M20				
DHGM-10X-4080	1-1/2 BSP.F	3/8 BSP.F	M20	156 (6.14)	74 (2.91)	194.5 (7.66)	112.5 (4.43)
DHGM-10X-4090	1-1/2 NPT	3/8 NPT	3/4-10 UNC				

Note: Uses of port "X", "Y", "V", and "W"

Valve Types		Pilot Pres. Port "X"	Port "Y"	Drain Port "V"	Drain Port "W"	
Solenoid Controlled Pilot Operated Directional Valves	Spring Centred, No-spring, Spring Offset	Used only on external pilot type valves.	Used as drain port only on external drain type valves.	Not used (plug is not required)		
	Pressure Centred			Used	Not used	
	With Pilot Piston, Both Ends	To be plugged on internal pilot type valves.	To be plugged on* internal drain type valves.	Used	Used	
	With Pilot Piston, Port "A" End			Used	Not used (plug is required)	
With Pilot Piston, Port "B" End			Not used (plug is required)	Used		
Pilot Operated Directional Valves	Spring Centred, No-spring	Used	Used as pilot pres. port	Not used (plug is not required)		
	Spring Offset		Used as pilot drain port			
	Pressure Centred			Used	Not used	
	With Pilot Piston, Both Ends		Used as pilot pres. port	Used	Used	
	With Pilot Piston, Port "B" End				Not used (plug is required)	Used
	With Pilot Piston Port "A" End		Spring Centred	Used as pilot pres. port	Used	Not used (plug is required)
	No-spring	Used as pilot drain port				
	Spring Offset					
Manually Operated Directional Valves		Not used (plug is not required)	Not used (plug is not required)	Used	Not used (plug is not required)	

* As the thread is provided on the body, plug either port on the sub-plate or port on the body.

Options

Models with Pilot Choke Valve

Terminal Box Type

- DSHG-03- ***-C1/C2/C1C2

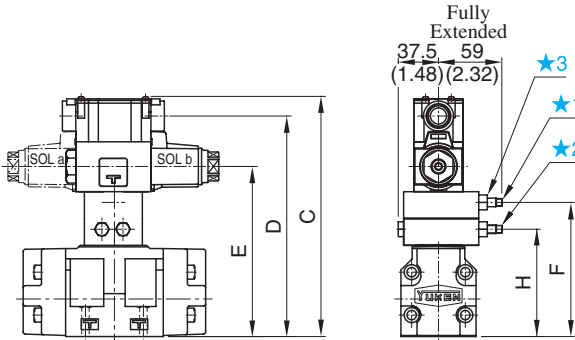

- (S)-DSHG-04- ***-C1/C2/C1C2

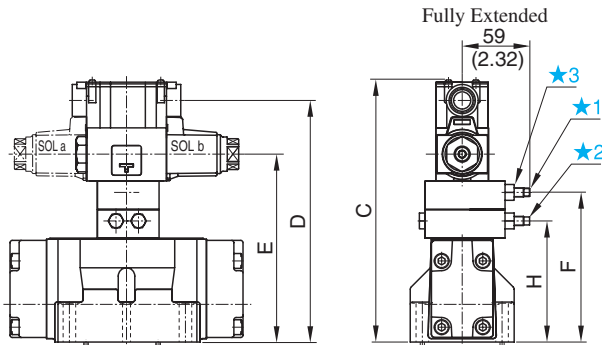

- (S)-DSHG-06₁₀ - ***-C1/C2/C1C2

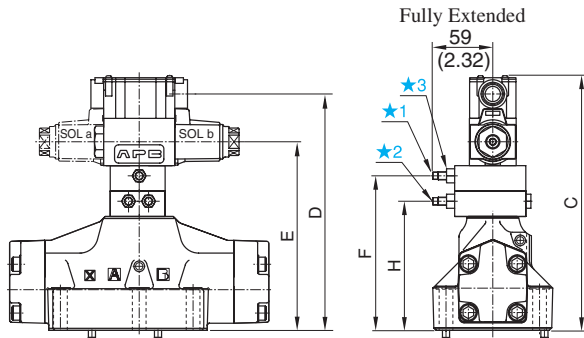

Plug-in Connector Type

- DSHG-03- ***-C1/C2/C1C2-N_{N1}

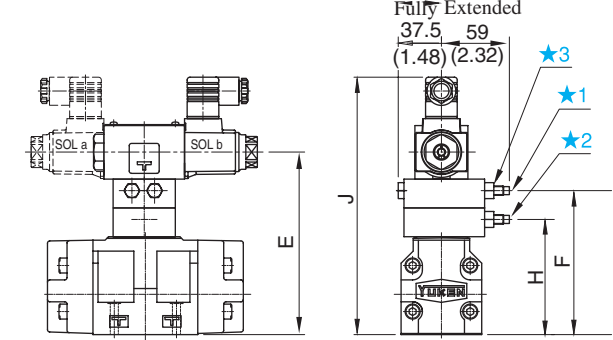

- (S)-DSHG-04- ***-C1/C2/C1C2-N_{N1}

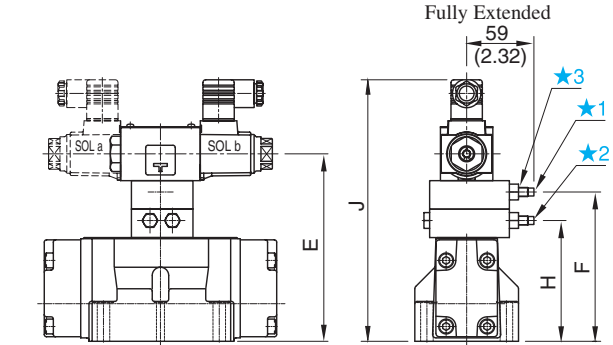

- (S)-DSHG-06₁₀ - ***-C1/C2/C1C2-N_{N1}

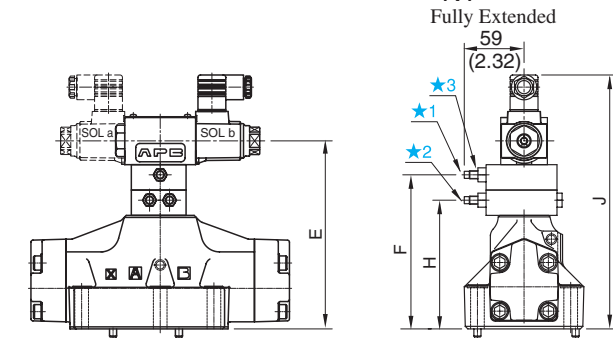

- ★1. "C1" Choke Adj. Screw 6 (.24) Hex.
- ★2. "C2" Choke Adj. Screw 6 (.24) Hex.
- ★3. Lock Nut 12 (.47) Hex.

DIMENSIONS IN MILLIMETRES (INCHES)

Model Numbers	Dimensions mm (Inches)								
	C	D	E	F	H	J			
						AC SO L	DC SO L	R SOL	
DSHG-03- *** -C1	198.8 (7.83)	180.5 (7.11)	133.5 (5.26)	100 (3.94)	—	198.5 (7.81)	209.5 (8.25)	212.5 (8.37)	
DSHG-03- *** -C2				—	100 (3.94)				
DSHG-03- *** -C1C2	223.8 (8.81)	205.5 (8.09)	158.5 (6.24)	125 (4.92)	100 (3.94)	223.5 (8.80)	234.5 (9.23)	237.5 (9.35)	
(S-) DSHG-04- *** -C1	204.8 (8.06)	186.5 (7.34)	139.5 (5.49)	106 (4.17)	—	204.5 (8.05)	215.5 (8.48)	218.5 (8.60)	
(S-) DSHG-04- *** -C2				—	106 (4.17)				
(S-) DSHG-04- *** -C1C2	229.8 (9.05)	211.5 (8.33)	164.5 (6.48)	131 (5.16)	106 (4.17)	229.5 (9.04)	240.5 (9.47)	243.5 (9.59)	
(S-) DSHG-06- *** -C1	225.8 (8.89)	207.5 (8.17)	160.5 (6.32)	127 (5.00)	—	225.5 (8.88)	236.5 (9.31)	239.5 (9.43)	
(S-) DSHG-06- *** -C2				—	127 (5.00)				
(S-) DSHG-06- *** -C1C2	250.8 (9.87)	232.5 (9.15)	185.5 (7.30)	152 (5.98)	127 (5.00)	250.5 (9.86)	261.5 (10.30)	264.5 (10.41)	
(S-) DSHG-10- *** -C1	288.8 (11.37)	270.5 (10.65)	223.5 (8.80)	190 (7.48)	—	288.5 (11.36)	299.5 (11.79)	302.5 (11.91)	
(S-) DSHG-10- *** -C2				—	190 (7.48)				
(S-) DSHG-10- *** -C1C2	313.8 (12.35)	295.5 (11.63)	248.5 (9.78)	215 (8.46)	190 (7.48)	313.5 (12.34)	324.5 (12.78)	327.5 (12.89)	

Options

Models with Stroke Adjustment

● DSHG-03-***-R*

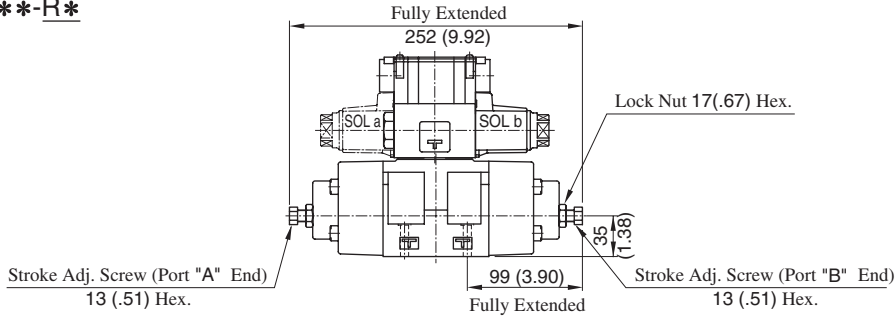

● (S-)DSHG-04-***-R*

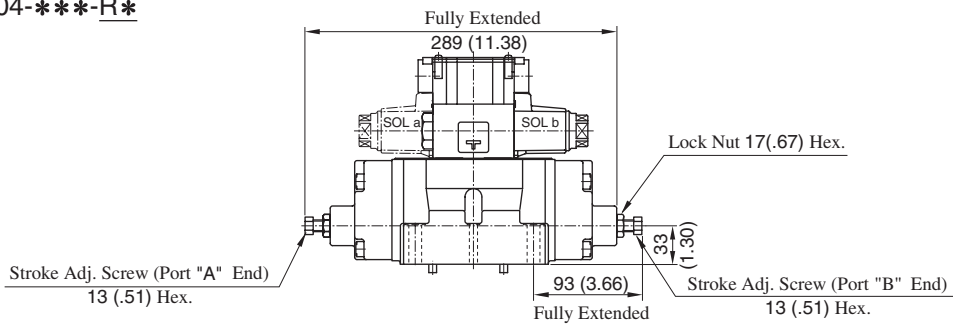

● (S-)DSHG-06-10-***-R*

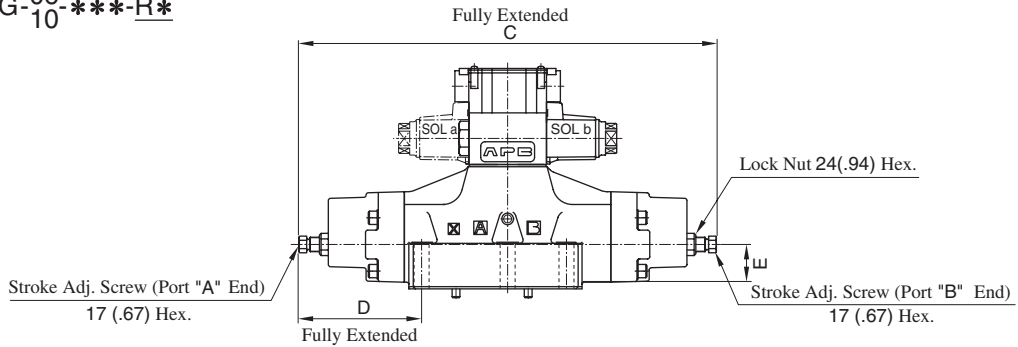

Model Numbers	C	D	E
(S-)DSHG-06-***-R2	376 (14.80)	111 (4.37)	40 (1.57)
(S-)DSHG-10-***-R2	558 (21.97)	164.5 (6.48)	65 (2.56)

DIMENSIONS IN MILLIMETRES (INCHES)

Pressure Centred Models

● (S-)DSHG-06-10-3H*

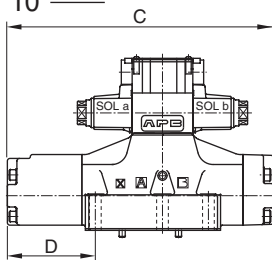

Model Numbers	C	D
(S-)DSHG-06-3H*	306.5 (12.07)	102 (4.02)
(S-)DSHG-10-3H*	456 (17.95)	149.5 (5.89)

Models with Pilot Piston

● (S-)DSHG-06-10-***-P*

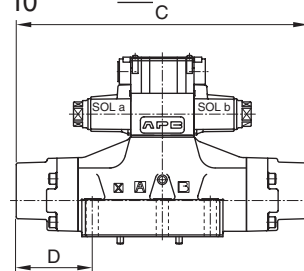

Model Numbers	C	D
(S-)DSHG-06-***-P2	323 (12.72)	84 (3.31)
(S-)DSHG-10-***-P2	479 (18.86)	125 (4.92)

■ List of Seals and Pilot Valves

DSHG-01-***-14/1480/1490

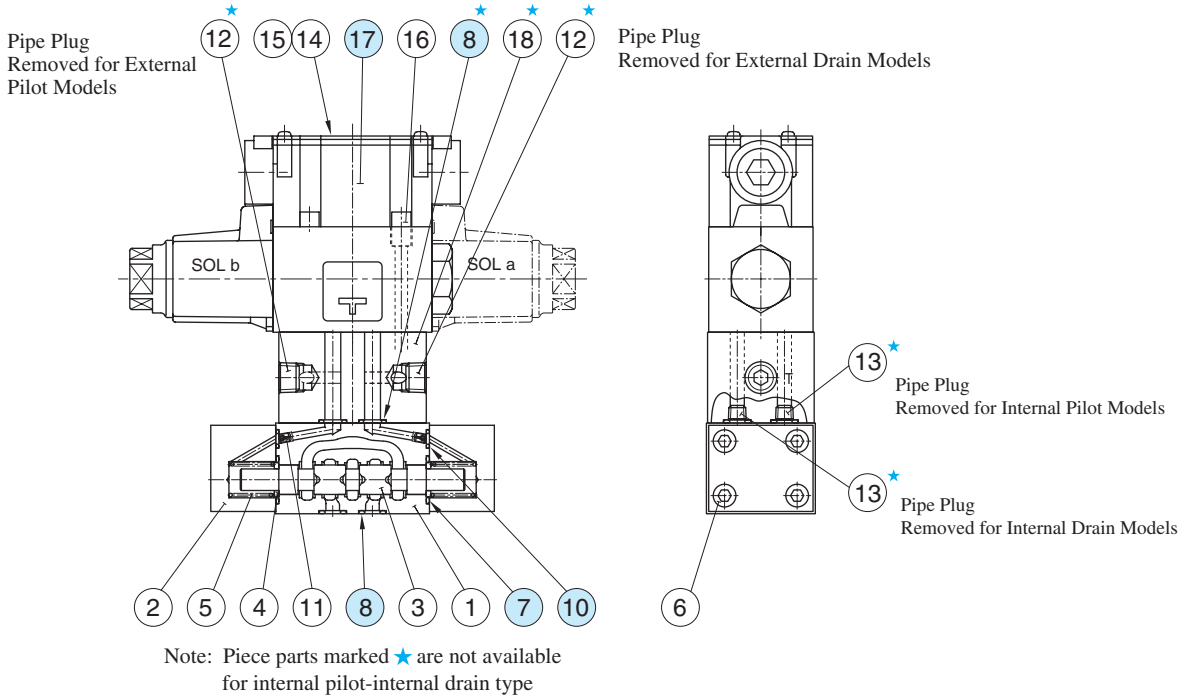

DSHG-03-***-14/1490

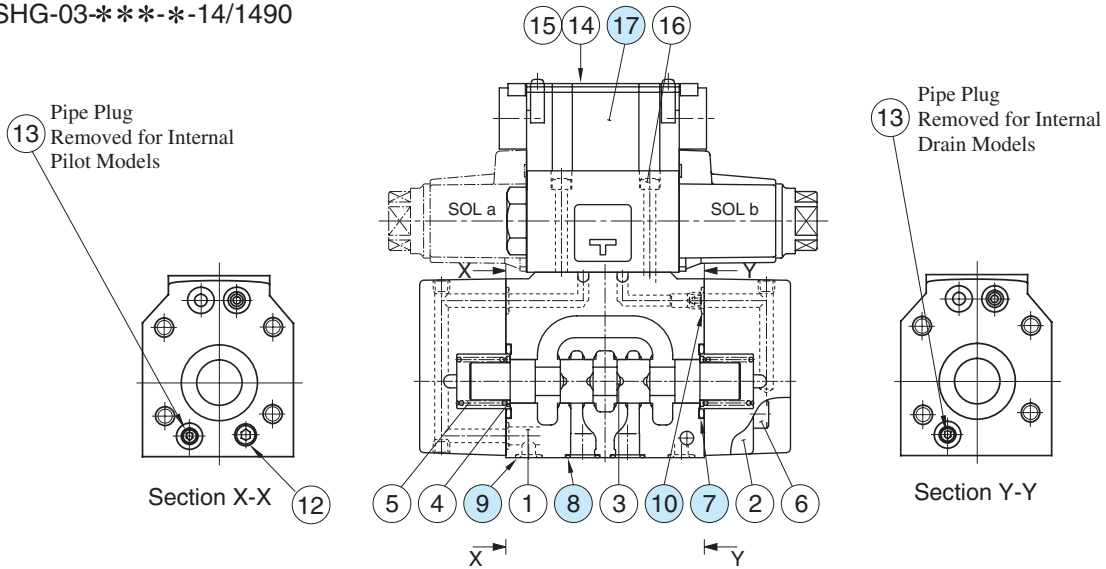

● List of Seals

Item	Name	DSHG-01		DSHG-03	
		Part Numbers	Qty.	Part Numbers	Qty.
7	O-Ring	JASO-1018-1A	2	SO-NB-P28	2
8	O-Ring	SO-NB-P9	8(4)★	SO-NB-A104	5
9	O-Ring	—	—	SO-NB-P9	2
10	O-Ring	SO-NB-P5	2	SO-NB-P9	6

★ Quantities in the () are applicable to internal pilot-internal drain.

Note: When ordering the o-rings, please specify the seal kit number listed in page 28. In addition to the above o-rings, o-rings for pilot valve is included in the seal kit.

For the detail of the pilot valve o-rings, see page 359.

● Pilot Valves

See page 28 for the pilot valve model numbers to be used.

■ List of Seals and Pilot Valves

(S-)DSHG-04-***-52/5290

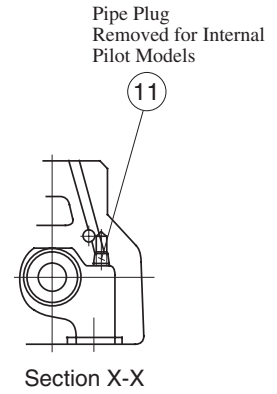
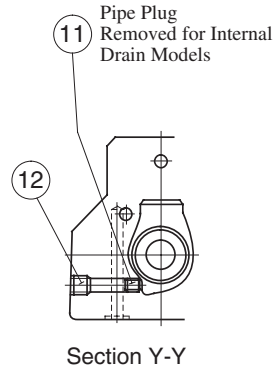
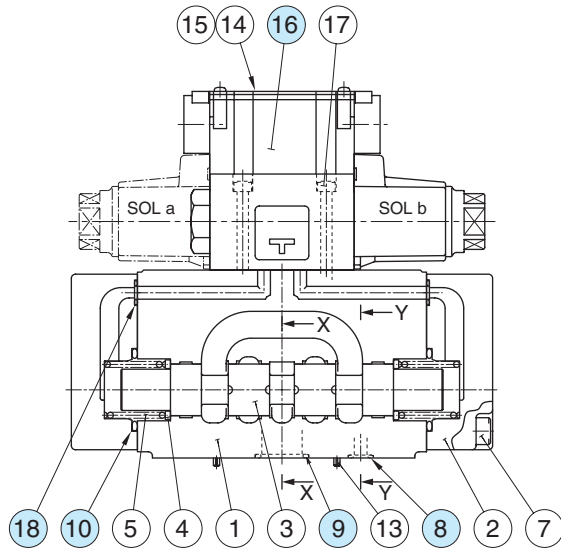

(S-)DSHG-06-***-53/5390

(S-)DSHG-10-***-43/4390

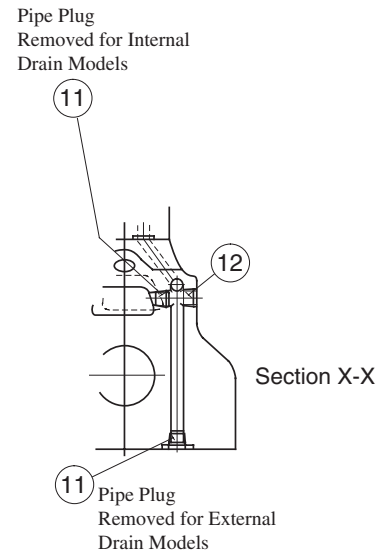
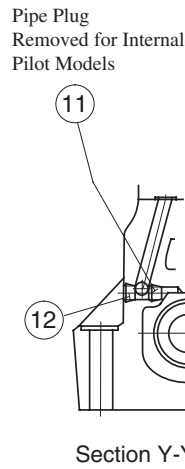
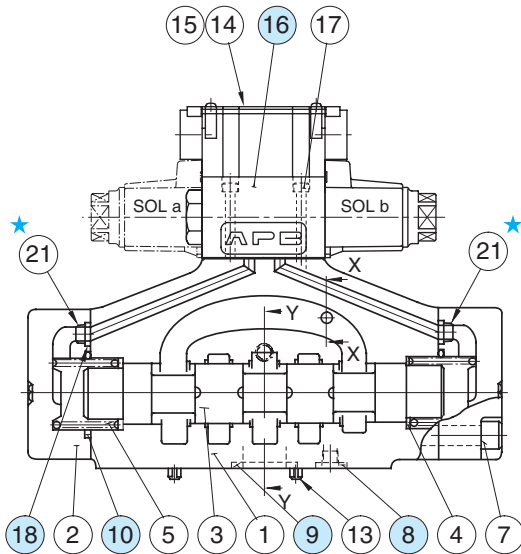

Note: Item ② orifice marked ★ is applicable to pressure centred models (3H*) with pilot pressure more than 10 MPa (1450 PSI).

● List of Seals

Item	Name	Part Numbers			Qty.
		(S-)DSHG-04	(S-)DSHG-06	(S-)DSHG-10	
8	O-Ring	SO-NB-P9	SO-NB-P14	SO-NB-P20	2
9		SO-NB-P22	SO-NB-P30	SO-NB-P42	4
10		SO-NB-P34	SO-NB-P40	SO-NB-P65	2
18		SO-NB-P9	SO-NB-P10	SO-NB-P14	2

● Pilot Valves

See page 28 for the pilot valve model numbers to be used.

Note: When ordering the o-rings, please specify the seal kit number listed in page 28. In addition to the above o-rings, o-rings for pilot valve is included in the seal kit.
For the detail of the pilot valve o-rings, see page 359.

■ List of Seal Kits and Pilot Valves

Valve Model Numbers	Pilot Valve Model Numbers	Seal Kit Numbers
DSHG-01-3C*-★-▲-14 DSHG-01-3C*-★-N-1480 DSHG-01-3C*-★-▲-1490	DSG-01-3C4-★-▲-70 DSG-01-3C4-★-N-70 DSG-01-3C4-★-▲-7090	KS-DSHG-01-▲-14 (For Internal Pilot-Internal Drain)
DSHG-01-2B*-★-▲-14 DSHG-01-2B*-★-N-1480 DSHG-01-2B*-★-▲-1490	DSG-01-2B2-★-▲-70-L DSG-01-2B2-★-N-70-L DSG-01-2B2-★-▲-7090-L	KS-DSHG-01-ET-▲-14 (Except for Internal Pilot-Internal Drain)
DSHG-03-3C*-★-▲-14 DSHG-03-3C*-★-▲-1490	DSG-01-3C4-★-▲-70 DSG-01-3C4-★-▲-7090	KS-DSHG-03-▲-14
DSHG-03-2B*-★-▲-14 DSHG-03-2B*-★-▲-1490	DSG-01-2B2-★-▲-70 DSG-01-2B2-★-▲-7090	
DSHG-03-2N*-★-▲-14 DSHG-03-2N*-★-▲-1490	DSG-01-2D2-★-▲-70 DSG-01-2D2-★-▲-7090	
(S-)DSHG-04-3C*-★-▲-52 (S-)DSHG-04-3C*-★-▲-5290	DSG-01-3C4-★-▲-70 DSG-01-3C4-★-▲-7090	KS-DSHG-04-▲-52
(S-)DSHG-04-2B*-★-▲-52 (S-)DSHG-04-2B*-★-▲-5290	DSG-01-2B2-★-▲-70 DSG-01-2B2-★-▲-7090	
(S-)DSHG-04-2N*-★-▲-52 (S-)DSHG-04-2N*-★-▲-5290	DSG-01-2D2-★-▲-70 DSG-01-2D2-★-▲-7090	
(S-)DSHG-06-3C*-★-▲-53 (S-)DSHG-06-3C*-★-▲-5390	DSG-01-3C4-★-▲-70 DSG-01-3C4-★-▲-7090	KS-DSHG-06-▲-53
(S-)DSHG-06-2B*-★-▲-53 (S-)DSHG-06-2B*-★-▲-5390	DSG-01-2B2-★-▲-70-L DSG-01-2B2-★-▲-7090-L	
(S-)DSHG-06-2N*-★-▲-53 (S-)DSHG-06-2N*-★-▲-5390	DSG-01-2D2-★-▲-70 DSG-01-2D2-★-▲-7090	
(S-)DSHG-10-3C*-★-▲-43 (S-)DSHG-10-3C*-★-▲-4390	DSG-01-3C4-★-▲-70 DSG-01-3C4-★-▲-7090	KS-DSHG-10-▲-43
(S-)DSHG-10-2B*-★-▲-43 (S-)DSHG-10-2B*-★-▲-4390	DSG-01-2B2-★-▲-70-L DSG-01-2B2-★-▲-7090-L	
(S-)DSHG-10-2N*-★-▲-43 (S-)DSHG-10-2N*-★-▲-4390	DSG-01-2D2-★-▲-70 DSG-01-2D2-★-▲-7090	

Notes) 1: Fill coil type (a symbol representing current/voltage) in section marked ★. Likewise, in section marked ▲, fill a symbol representing the type of electrical conduit connection (None: Terminal Box Type, N: Plug-in Connector Type).
2: For the details of the pilot valves, see [page 359 to 360](#).