

GETM5.0H



Max. axle load	5000kg
Motor weight	540kg
Working duty	S5-40%ED
Protection class	IP 40

Specification table

Product type	Traction Ratio	Load (kg)	Brake Speed (m/s)	Rated speed (rpm)	Wind type (k.m.g)	Motor					Brake				Sheave			
						Power (kW)	Voltage (V)	Current (A)	Poles (p)	Frequency (Hz)	Current (A)	Voltage (V)	Release (k.m.g)	Shaft size (mm)	Rope (mm)	β angle	γ angle	Wire pitch (mm)
GETM5.OH-250/1250	2:1	1250	2.5	212	940	20.9	340	47	16	56.6	2x1.15	Dc110	2x1270	450	4ø10	96°	35°	15
GETM5.OH-200/1250			2.0	170		16.7		38		45.3								
GETM5.OH-160/1250			1.6	136		13.4		30		36.2								
GETM5.OH-100/1250	2:1	1350	1.0	85	1050	8.4	340	19	16	22.6	2x1.15	Dc110	2x1270	450	8ø10	96°	35°	15
GETM5.OH-250/1350			2.5	212		22.6		50		56.6								
GETM5.OH-200/1350			2.0	170		18.0		40		45.3								
GETM5.OH-160/1350	2:1	1350	1.6	136	1050	14.4	340	32	16	36.2	2x1.15	Dc110	2x1270	450	8ø10	96°	35°	15
GETM5.OH-100/1350			1.0	85		9.0		20		22.6								

Overall Dimensions

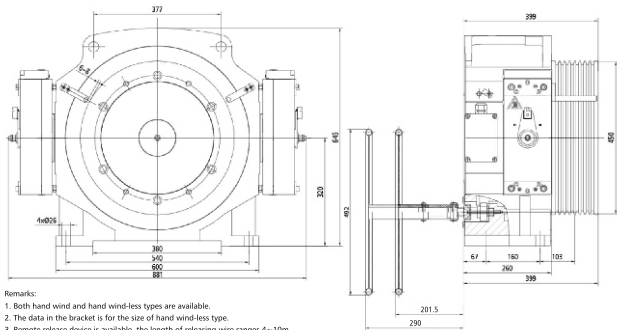

Remarks:

1. Both hand wind and hand wind-less types are available.
2. The data in the bracket is for the size of hand wind-less type.
3. Remote release device is available, the length of releasing wire ranges 4–10m.

