

RCG-03-06

Pressure Reducing with Check Valves(Sub-Plate Type)

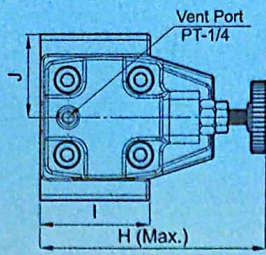

Valve Specifications & Attachment

Model	RCG-03	RCG-06
Flow Rating	50 lpm (13.2 gpm)	125 lpm (33 gpm)
Max. Pressure	250 bar (3600 psi)	250 bar (3600 psi)
Weight kg/(lbs.)	5.4 (11.9)	8.1 (17.9)
CODE:20	M10 X70LgX4pcs	M10 X80LgX4pcs
CODE:2090	3/8-16UNCX2-3/4LgX4pcs	3/8-16UNCX3-1/4LgX4pcs
Surface O-Ring	P9X1pc, P18X2pc	P9X2pc, P29X2pc
ISO Mounting	5781-AG-06-2-A	5781-AH-08-2-A



SYMBOL

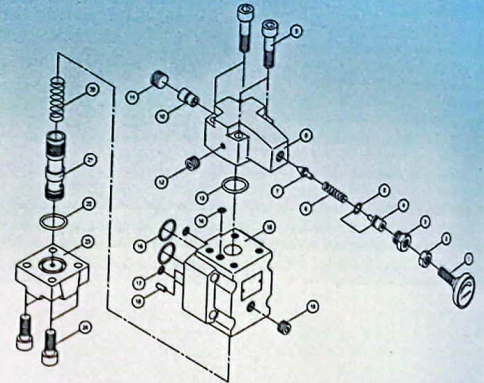
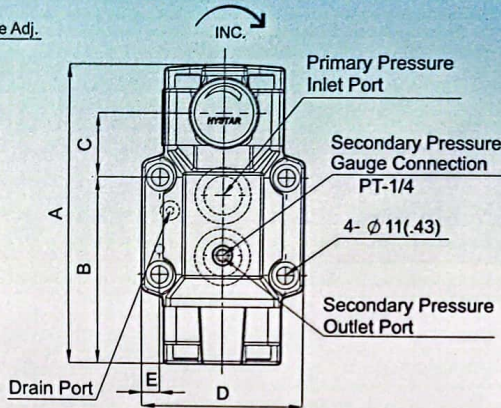
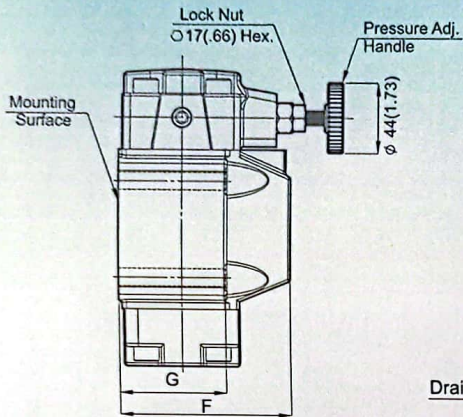

Model	A	B	C	D	E	F	G	H	I	J
RCG-03	158.5(6.24)	93.5(3.68)	40.5(1.59)	89(3.50)	11.2(.44)	90(3.54)	58(2.28)	144.5(5.68)	59(2.32)	44.5(1.75)
RCG-06	186(7.32)	116.5(4.58)	40(1.57)	102(4.01)	11.3(.44)	104(4.09)	68(2.67)	142.5(5.61)	69(2.71)	51(2.00)

RCT-03-06

Pressure Reducing with Check Valves(Threaded Type)

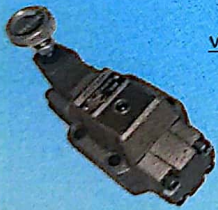
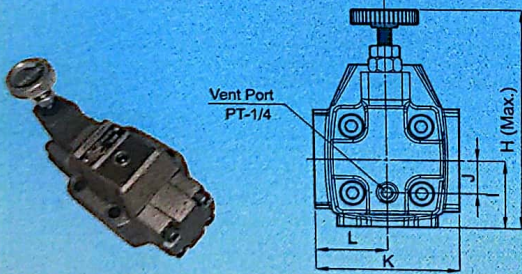

Valve Specifications & Attachment

Model	RCT-03	RCT-06
Flow Rating	50 lpm (13.2 gpm)	125 lpm (33 gpm)
Max. Pressure	250 bar (3600 psi)	250 bar (3600 psi)
Weight kg/(lbs.)	4.8 (10.6)	7.8 (17.2)
CODE:20	3/8" PT	3/4" PT
CODE:2090	3/8" NPT	3/4" NPT



SYMBOL

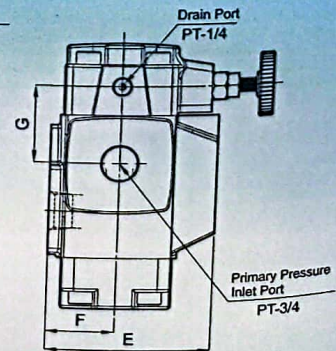
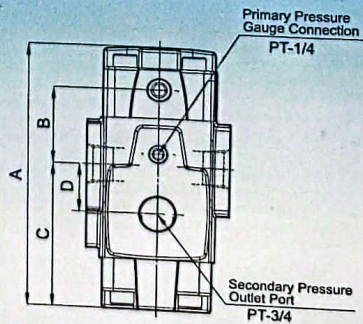
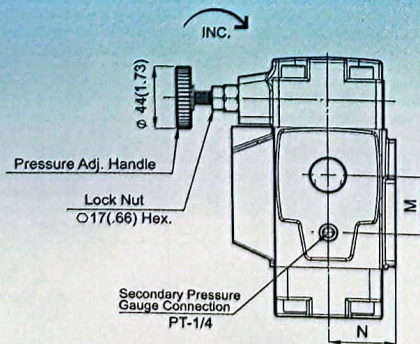

Model	A	B	C	D	E	F	G	H	I	J	K	L	M	N
RCT-03	158.5(6.24)	48(1.88)	86(3.38)	30(1.18)	95(3.74)	41.5(1.63)	47(1.85)	151(5.94)	41.5(1.63)	15.5(.61)	80(3.14)	40(1.57)	30(1.18)	41.5(1.63)
RCT-06	186(7.32)	53(2.08)	103(4.05)	34(1.33)	111(4.37)	46(1.81)	53(2.08)	148.5(5.84)	46(1.81)	22.5(.88)	96(3.77)	48(1.88)	41.5(1.63)	46(1.81)